

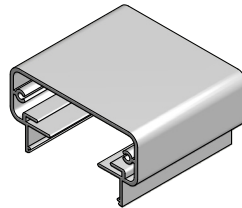

ASDTM
AMERICAN
STRUCTURES & DESIGN

TR200/999
CABLE



TR200 Rail

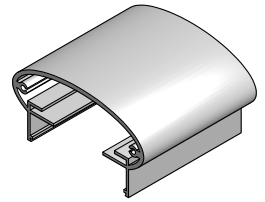

TR999 Rail

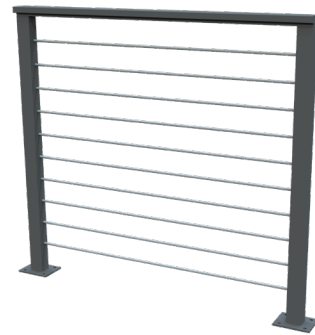

Cable Infill

INSTALLATION INSTRUCTIONS

Recommended Tools

1. Pencil
2. Tape measure
3. Level
4. Square
5. String line
6. Rubber mallet
7. Drill/impact driver
8. Electric miter saw with a 10" carbide blade with minimum 65 teeth (improve performance with additional teeth, optimal blade has 100 teeth)
9. Drill bits = $\frac{7}{16}$ " (for flush mount)
10. Screw driver bits = #2 Phillips, #2 Square Drive $\frac{3}{8}$ " (pre-drilling for lags) and a T-40 Allen (socket) head bit
11. Screwdriver bit holder
12. $\frac{3}{16}$ " Allen hex wrench
13. Cutoff wheel
14. Optional: cable pliers

Cable Infill Components: 1/8" and 3/16" Cable

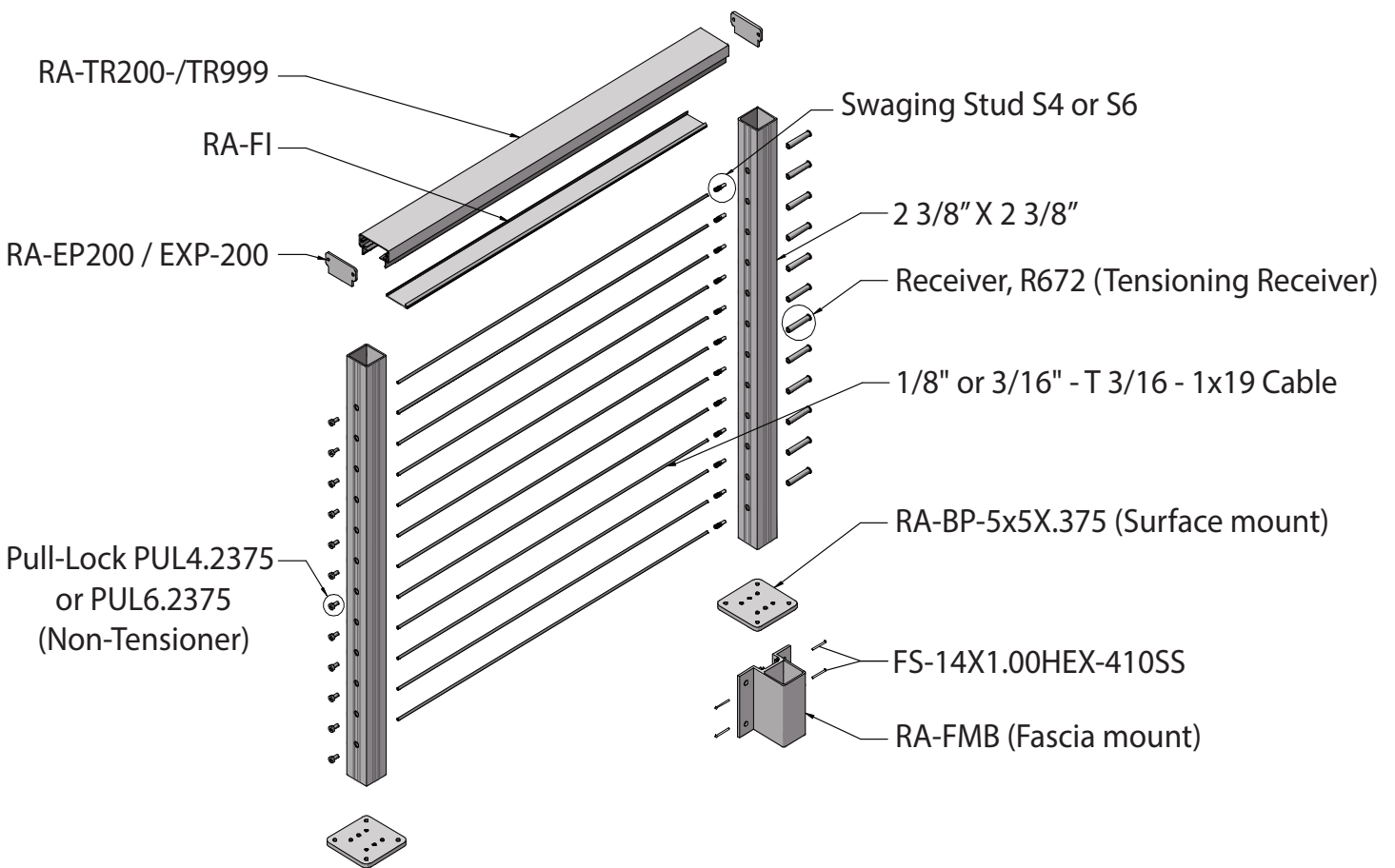

Preparation

1 Check materials – Verify all parts have arrived, and match the packing slip.

2

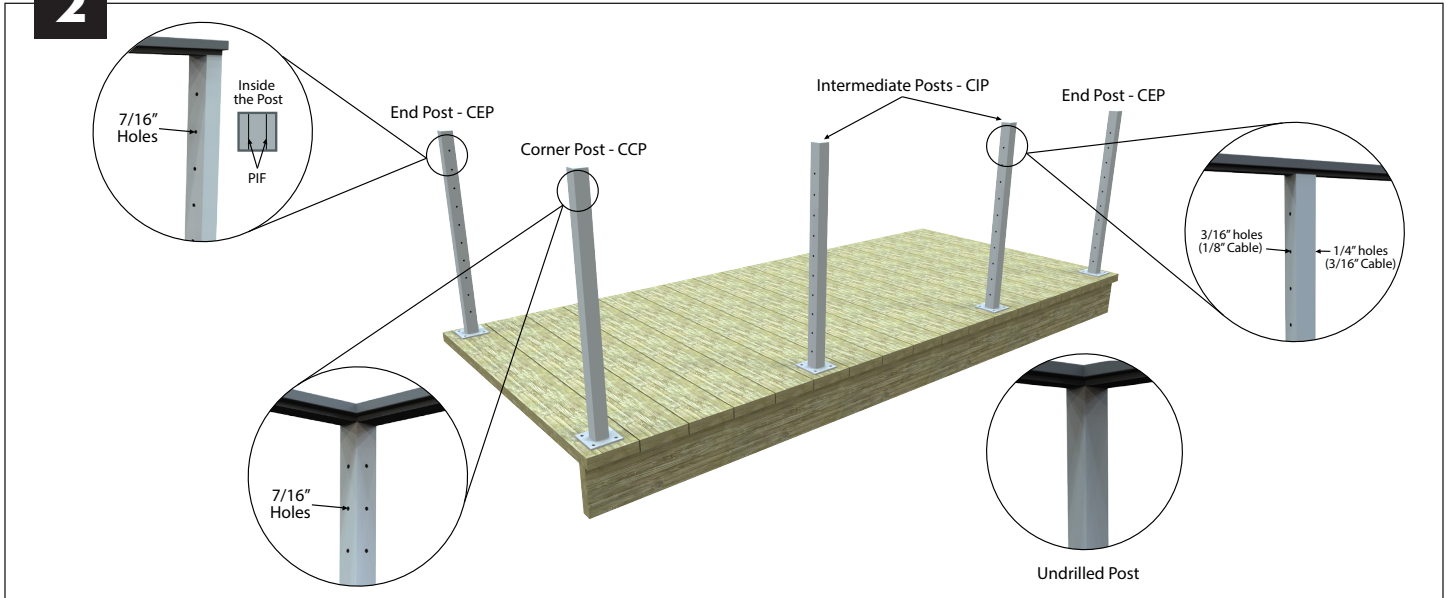

Gather and identify all posts per your layout - Maximum spacing is 4'-6" (Based on ASD Engineering) - Set end posts then space intermediate posts equally between end and corner posts.

Anchor Posts

3

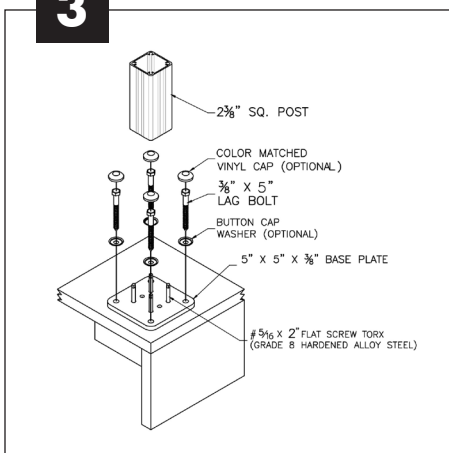

Surface mount – Anchor each post using (4 ea) $\frac{3}{8}$ " x 5" minimum lag bolts with washers and button caps.

4

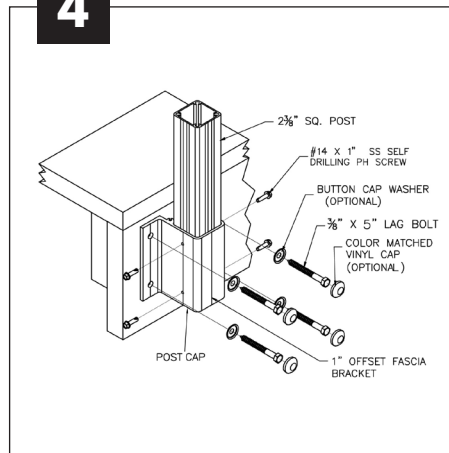

Fascia mount w/brackets – Anchor each fascia bracket using (4 ea) $\frac{3}{8}$ " x 5" minimum lag bolts with cap washer and button cap. Measure and cut each post to desired length. Secure the posts into the bracket using (2 ea side of fascia bracket) #14 x 1" tex screws. Cover the bottom of each post with a post cap using (1 ea) $\frac{3}{4}$ " painted screw to secure the post cap in place.

5

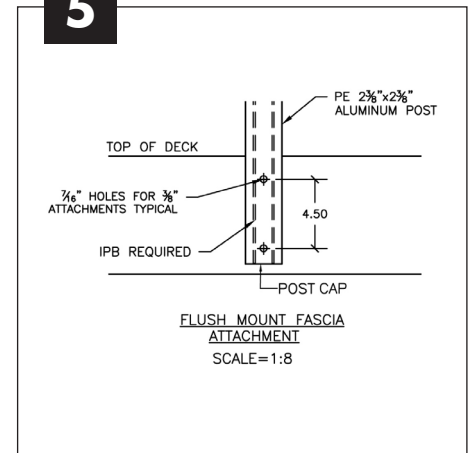

Fascia mount/flush – Measure and cut each post to desired length. Insert (2 ea) PIF into the bottom of each post. Cover the bottom of each post with a post cap and using (1 ea) $\frac{3}{4}$ " painted screw to secure post cap in place. Anchor each post using (2 ea) $\frac{3}{8}$ " x 7" minimum lag bolts with cap washer and button cap.

Connecting

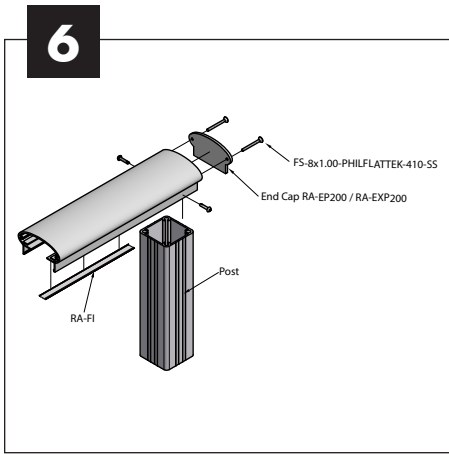

Top rail attachment – Install top rail and infill (RA-FI) first.

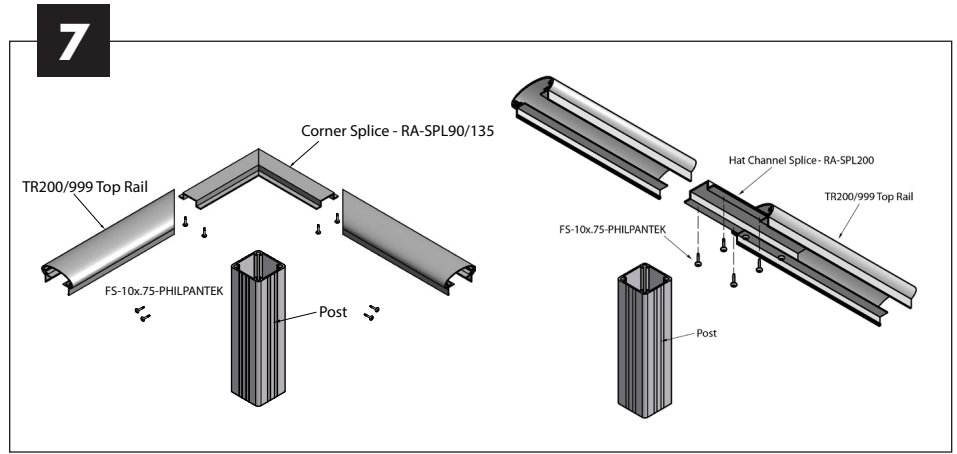

Corners and splicing – To create corners, top rail will be mitered, use the welded internal splice to secure miter. Secure splice to top rail using FS-10X.75-PHILPANTEK (4 on each side).

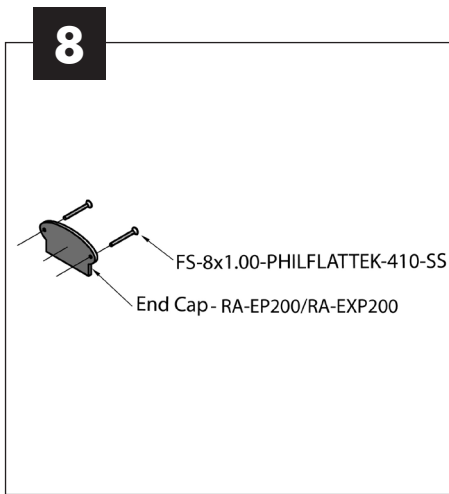

Terminating top rail – Cover end of top rail using end cap and secure with 2ea FX-8x1.00-PHILFLATTEK-410-SS

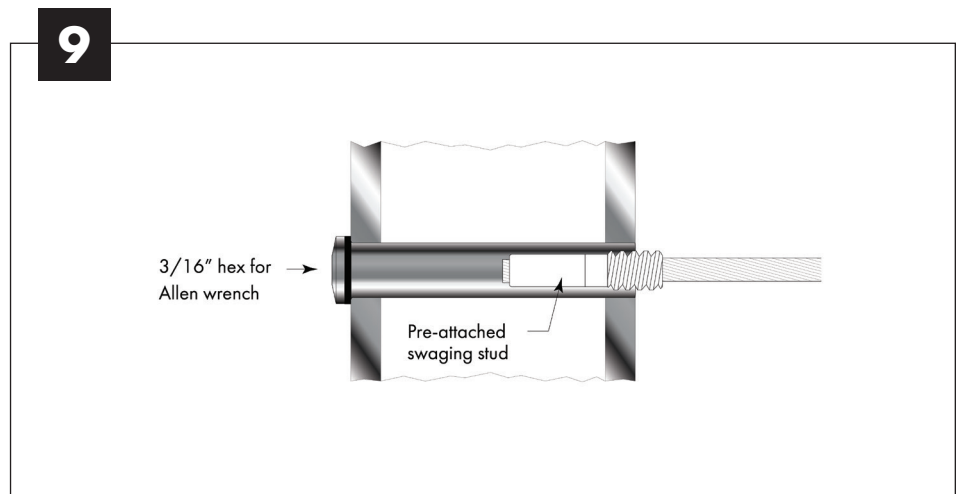

Receiver prep – Install the tensioning end first with the 2-3/8" long receiver. Slip the delrin washer over the body of the receiver and insert the receiver into the post. Start the threaded stud attached to the cable into the receiver and turn 3 complete turns. This will thread about 1/2 of the stud into the receiver.

10

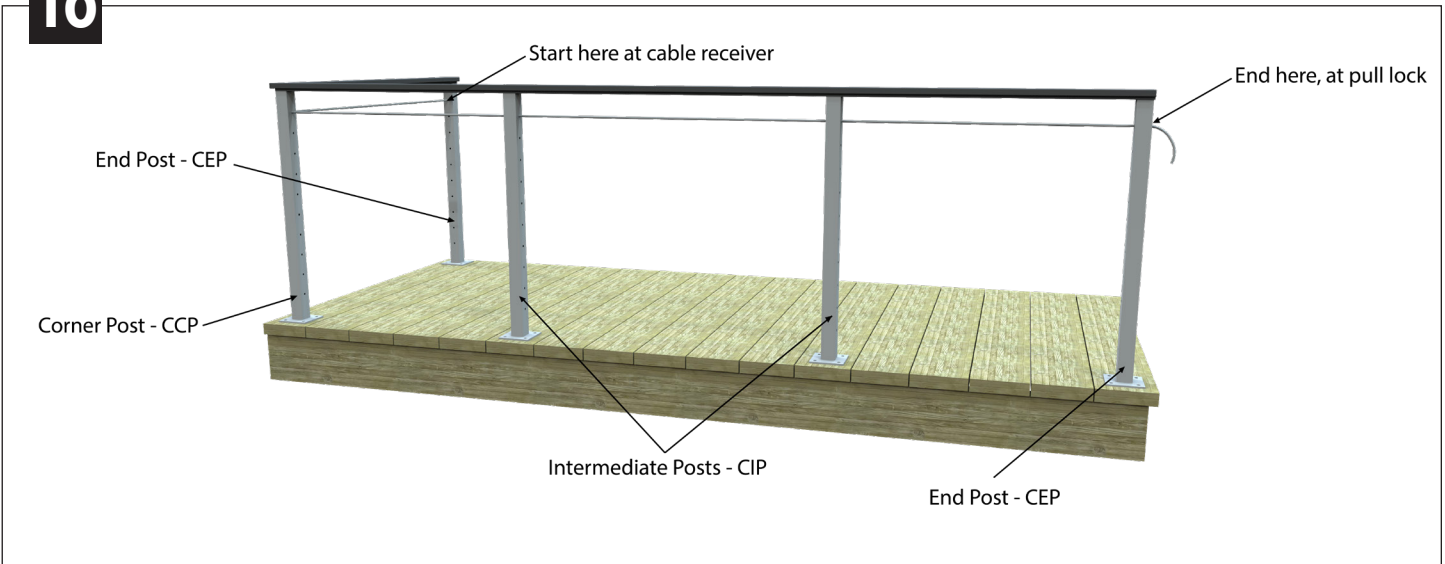

Installing cable – Run the bare end of the cable through all your intermediate posts and through the end post where you will be installing the pull-lock fitting.

11

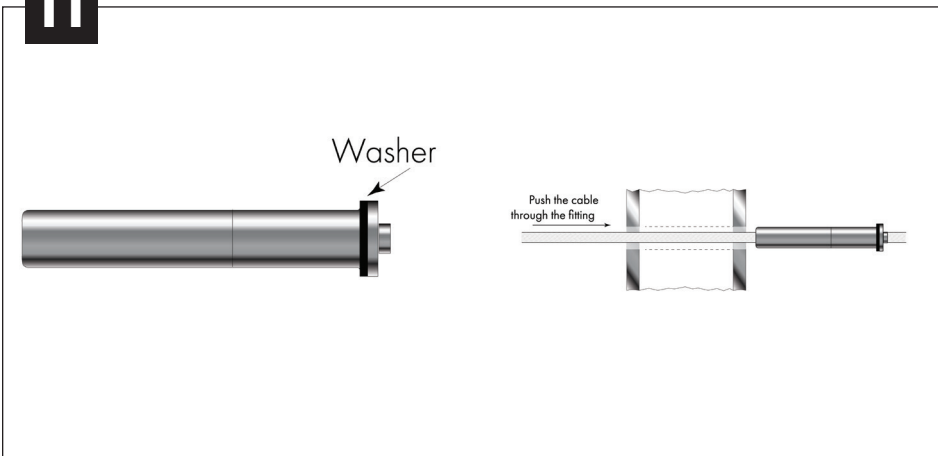

Pull-Lock prep – Slip the delrin washer over the body of the pull-lock fitting. Make sure cables have a clean cut and thread the cable through the CEP post at the end of the cable run. Push the cable into the hole in the front of the pull-lock fitting and pull the cable through. Twist the cable in the right hand direction as you push it into the fitting.

12

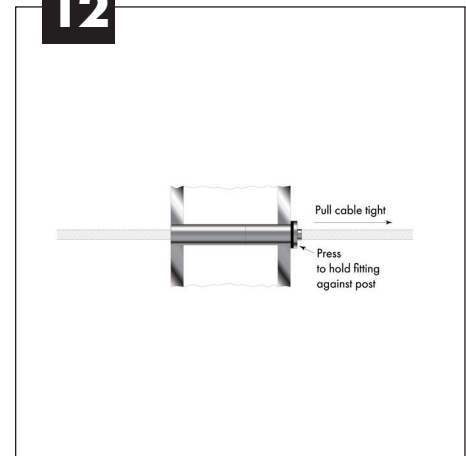

Installing Pull-Lock – Push the pull-lock fitting along the cable and firmly into the hole in your post. Push it in as tightly as you can with your hand while pulling the cable through as tightly as you can.

13

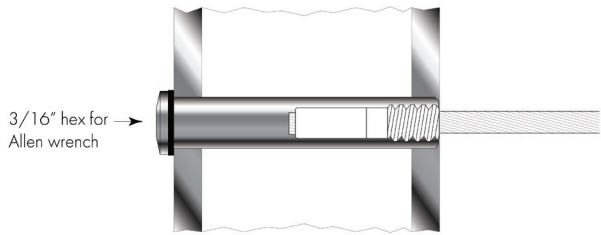

3/16" hex for Allen wrench

The swaging stud will be pulled into the Receiver by the tensioning.

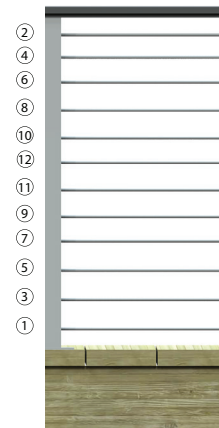

RECOMMENDED TENSIONING SEQUENCE

Tensioning cable – Go to the other end and tension the cable by holding the cable securely to prevent it from turning while you turn the receiver with an allen hex wrench. Be careful to protect the cable from damage while tensioning. Tension in sequence, beginning with the outside cables and moving back and forth toward the center. Finished cables should be tensioned to have only 1/4" of play when finger-pulled.

Note: Cable pliers are recommended for gripping cable.

14

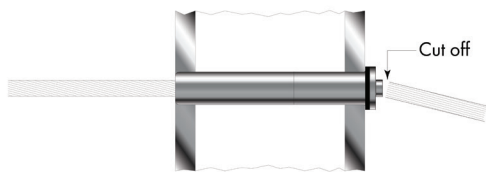

Cut off

Cut-off Tool
Used to cut cable flush with the end of the Pull-Lock fittings.

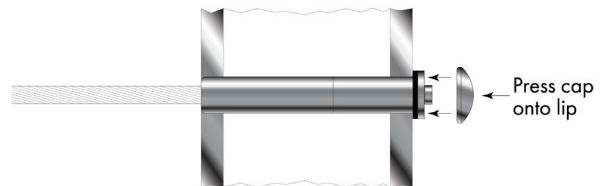

Press cap onto lip

Capping cable – Cut the cable flush with the hole in the back of the pull-lock fitting using a cut-off wheel. Press the cap onto the lip of the pull-lock fitting.