



CABLE HARDWARE CATALOG

Clean | Minimal | Transparent

TABLE OF CONTENTS

Items in this catalog are arranged by hardware fitting type.

SWAGED FITTINGS - TENSIONERS



Invisiware® Receivers - 3
Tensioner can be concealed inside metal or wood post



Adjust-A-Jaw® Tensioners - 4
Face-of-the-post-mounted fitting coupled with tab or lag



Adjust-A-Body® Tensioners - 6
Face-of-the-post-mounted fittings in four varieties for different post material

NON-TENSIONING FITTINGS



Invisiware® Radius Ferrule - 11
Through-the-post-mounted fitting can be concealed inside any post



Invisiware® Stud - 3, 11
Non-tensioning inside-the-post-mounted fitting for level or pitched runs swaged on to cable to be used with Invisiware® receiver



Fixed Jaw Tensioners - 12
Face-of-the-post-mounted fitting for level or pitched runs

SWAGELESS FITTINGS

TENSIONING



Invisiware® Receiver with Push-Lock® Stud - 15
Through-the-post-mounted fitting can be concealed inside the post



Push-Lock® Turnbuckle with Threaded Bolt - 16
Face-of-the-post-mounted fitting suitable for level runs only



Push-Lock® Tensioner with Hanger Bolt - 17
Face-of-the-post-mounted fitting suitable for level runs only



Push-Lock® Tensioner with Toggle - 17
Face-of-the-post-mounted fitting suitable for level runs only

NON-TENSIONING



Push-Lock® - 19
Through-the-post-mounted fitting for level runs only



Pull-Lock® - 23
Through-the-post-mounted fitting for level or pitched runs



Push-Lock® Toggle - 22
Face-of-the-post-mounted fitting for level runs only

CONCRETE FITTINGS



Adjust-A-Body® with Concrete Anchor Bolt - 25
Tensioning face-of-the-surface-mounted fittings for level runs terminating at concrete surface



Push-Lock® Concrete Anchor Bolt - 26
Non-tensioning face-of-the-surface-mounted fitting for level runs

EQUIPMENT & ACCESSORIES - 27-32

TABLE OF CONTENTS

Continued items in this catalog are arranged by category and page number.

SWAGED TENSIONING FITTINGS

Invisiware® Receiver with Invisiware® Stud	3
Invisiware® Stud	3
Stainless Steel Post Protector Tube	4
716SAE Stainless Steel Washer	4
Adjust-A-Jaw® and Threaded Tab	4
Invisiware® Threaded Tab	5
Lag Eye and Extended Length Lag Eye.....	5
Mounting Screw	5
Adjust-A-Body® with Hanger Bolt.....	6
Adjust-A-Body® with Extended Length Hanger Bolt.....	6
Adjust-A-Body® with Threaded Bolt	7
Ferrule	7
Adjust-A-Body® with Clevis.....	8
Adjust-A-Body® with Toggle.....	9

SWAGED NON-TENSIONING FITTINGS

Invisiware® Radius Ferrule	11
Invisiware® Stud.....	11
Fixed Jaw and Threaded Tab or Lag Eye.....	12
Clip-On Fixed Jaw and Threaded Tab or Lag Eye.....	13

SWAGELESS TENSIONING FITTINGS

Invisiware® Receiver with Push-Lock® Stud.....	15
Push-Lock® Stud	15
Push-Lock® Tensioner with Threaded Bolt	16
Push-Lock® Tensioner with Threaded Clevis	16
Push-Lock® Turnbuckle with Threaded Bolt.....	16
Push-Lock® Tensioner with Hanger Bolt.....	17
Push-Lock® Tensioner with Lag Clevis.....	17
Push-Lock® Tensioner with Toggle.....	18

SWAGELESS NON-TENSIONING FITTINGS

Push-Lock®	20
Push-Lock® Threaded Bolt	21
Push-Lock® Threaded Clevis	21
Push-Lock® Lag	22
Push-Lock® with Lag Clevis.....	22
Push-Lock® with Toggle	22
Pull-Lock®	23-24
Swaged Adjust-A-Body with concrete anchor bolt.....	25
Push-Lock® with Concrete Anchor Bolt	26

EQUIPMENT / ACCESSORIES / RAILING COMPONENTS

650 Swager Rental Kit.....	27
610 Swager Rental Kit.....	27
Electric Hydraulic 120V Pump	28
650 Shipping Container/Tool Box	28
Air Over Hydraulic Pump.....	28
610 Shipping Container/Tool Box	28
Cable Cutter	28
Cable Gripping Pliers	28
Cable Release	28
PL Lag Driver.....	28
Radius Ferrule Gauge	28
Grommet Installation Tool Set	28
Cable Tension Gauge.....	29
Industrial Pre-Tensioner.....	29
Pre-Tensioner	29
Pre-Tensioner Locking Pliers.....	29
Drill Guide	29
Stainless Steel Spacers	29
Beveled Washers	30
Stainless Steel Cleaner and Protectant	30
Cables (Five Sizes)	30
Cut-off Tool.....	30
Isolation Bushing	30
Stainless Steel Cable Brace.....	31
Stainless Steel Cable Brace Floor Plates	31
Stainless Steel Cable Brace for Stairs	31
Cable Grommets.....	32

ADDITIONAL INFORMATION

Cable Railing Reference Guide.....	33
------------------------------------	----

SWAGED FITTINGS - TENSIONERS

HARDWARE FOR METAL POSTS

- Invisiware® Receiver with Invisiware® Stud
- Adjust-A-Body® with Threaded Bolt
- Adjust-A-Jaw® with Invisiware® Tab
- Adjust-A-Body® with Clevis
- Adjust-A-Body® with Toggle



HARDWARE FOR WOOD POSTS & WOOD POSTS WITH SLEEVES

- Invisiware® Receiver with Invisiware® Stud
- Adjust-A-Body® with Hanger Bolt
- Adjust-A-Jaw® with Lag Eye
- Adjust-A-Body® with Lag Clevis

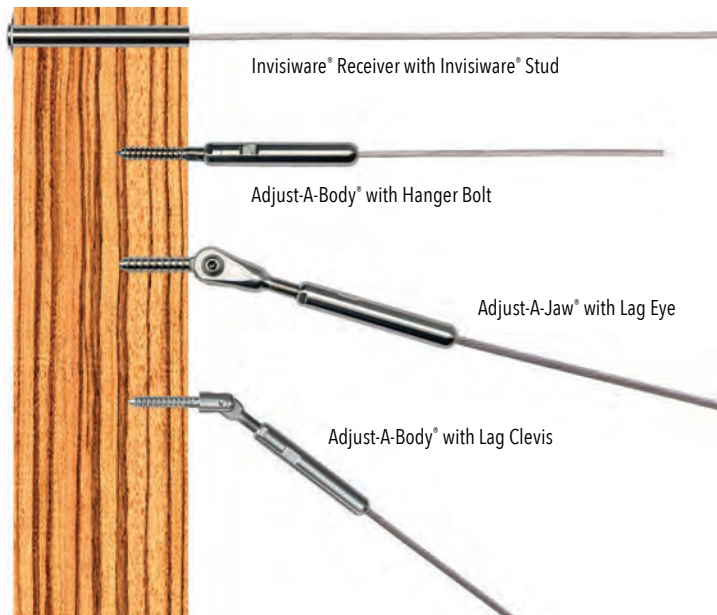

SWAGING REQUIRED: These fittings must be attached with swaging equipment capable of developing proper force based on the fittings' mass. Special equipment is required.



NON-TENSIONING FITTING: A fitting with this symbol is a non-tensioning fitting. Only one (1) non-tensioning fitting can be used on a cable run to be properly installed.

The Tensioners That Are Hidden Inside The Post

Invisiware® Receiver with Invisiware® Stud



Concealed, swaged, tensioning, through-the-post-mounted fitting suitable for level and pitched runs. Receivers and studs are available for 1/8", 3/16", 1/4", 5/16", and 3/8" diameter 1x19 stainless steel cable.

- The Invisiware® Receiver with Invisiware® Stud can be used with any other fitting on the opposite end of the run.
- Fitting is placed and concealed within a pre-drilled hole in the metal end post.
- Receiver is furnished with a Delrin® washer that is installed between the shoulder of the fitting and the end post to protect the surface of the finish of the end post as tension is applied.
- Stud is swaged onto one end of the cable and threaded into the Receiver installed in the end post. Tension is created by rotating the Receiver (with a hex wrench inserted into its broached end) and drawing the stud into the Receiver.

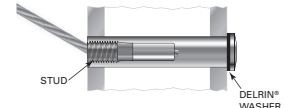
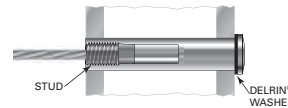
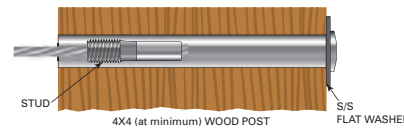
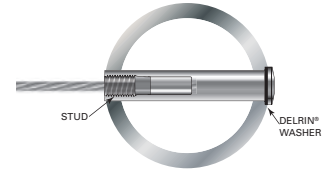

INVISIWARE® RECEIVER DIMENSIONS

CABLE DIAMETER	1/8" CABLE	3/16" CABLE	1/4" CABLE	5/16" CABLE	3/8" CABLE
Part Number	R-6-XX	R-6-XX	R-8-XX	R-12-XX	R-12-XX
"D" Diameter	.437"	.437"	.531"	.687"	.687"
"T" Thread	5/16-24	5/16-24	7/16-20	9/16-18	9/16-18
"H" Hex	3/16"	3/16"	7/32"	5/16"	5/16"
"S" Diameter	.537"	.537"	.646"	.865"	.865"
"L" Length	See "FRAMING OPTIONS" Table				

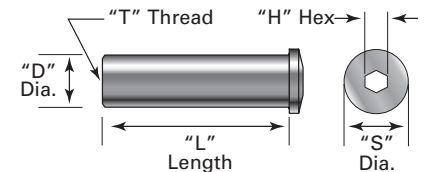

FRAMING OPTIONS FOR INVISIWARE® RECEIVER

CABLE DIAMETER	1/8" CABLE	1/8" CABLE	3/16" CABLE	3/16" CABLE	1/4" CABLE	5/16" CABLE	3/8" CABLE	"L" Length
FRAME OPTIONS	PART NO.	BRONZE PART	PART NO.	BRONZE PART	PART NO.	PART NO.	PART NO.	
1-1/2" Tube* or 1-1/4" Pipe	R-6-12	XR-6-12-B2	R-6-12	XR-6-12-B2	NA	NA	NA	1.56"
1-1/2" Pipe	R-6-22	XR-6-22-B2	R-6-22	XR-6-22-B2	R-8-22	NA	NA	1.81"
2"x2" Tube*	R-6-32	XR-6-32-B2	R-6-32	XR-6-32-B2	R-8-32	R-12-32	R-12-32	2.03"
2" Pipe	R-6-42	XR-6-42-B2	R-6-42	XR-6-42-B2	R-8-42	R-12-42	R-12-42	2.30"
2-3/8" Tube*	R-6-72	XR-6-72-B2	R-6-72	XR-6-72-B2	NA	NA	NA	2.405"
2-1/2" Tube*	R-6-82	XR-6-82-B2	R-6-82	XR-6-82-B2	R-8-82	NA	NA	2.53"
3" Tube*	R-6-52	XR-6-52-B2	R-6-52	XR-6-52-B2	R-8-52	R-12-52	R-12-52	3.03"
3-1/2" Tube*	R-6-62	XR-6-62-B2	R-6-62	XR-6-62-B2	NA	NA	NA	3.5625"
4x4 Min. Wood Post	R-6-62	XR-6-62-B2	R-6-62	XR-6-62-B2	NA	NA	NA	3.5625"

*Round or Square Tube

Invisiware® Stud



This part is swaged onto the end of the cable and used with the Invisiware® Receiver. The threaded surface is coated with a baked-on molybdenum-based dry film lubricant to prevent the threads from galling when tensioned.



Photo of stud before swaging.

TYPE 316 STAINLESS STEEL — MOLY COATED

CABLE DIA.	PART NO.	THREAD	"L"	"D" DIAMETER AFTER SWAGED
1/8"	S-4-TC	5/16-24	1.180"	.250"
3/16"	S-6-TC	5/16-24	1.140"	.250"
1/4"	S-8	7/16-20	1.380"	.375"
5/16"	S-10	9/16-18	1.330"	.500"
3/8"	S-12	9/16-18	1.310"	.500"

Stainless Steel Post Protector Tube

To keep the cable from biting in the wood, the Post Protector Tube is inserted into a wood post where the cable enters/exits the post at an angle.

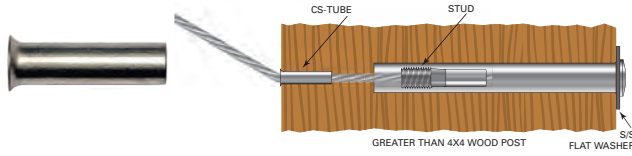

TYPE 316 STAINLESS STEEL

CABLE DIA.	TUBE LENGTH	PART NO.
1/8", 3/16"	3/4"	CS-TUBE

7/16SAE Stainless Steel Washer

To protect the wood when the Invisiware® Receiver is tensioned, install this on the shoulder of the Receiver.



TYPE 316 STAINLESS STEEL

PART NO.	WASHER O.D.	WASHER I.D.	USED WITH HARDWARE FOR CABLE DIAMETERS
7/16SAE	59/64"	31/64"	1/8" and 3/16"

Adjust-A-Jaw® and Threaded Tab



Exposed, swaged, tensioning, face-of-the-post-mounted fitting suitable for level or pitched runs. This fitting is available for 1/8", 3/16", 1/4", 5/16", and 3/8" diameter 1x19 stainless steel cable.

- Can be used with any fitting on the opposite end of the run.
- Attaches to the metal end post by installing a Threaded Tab into a pre-drilled tapped hole in the end post and attaching the Fixed Jaw to the Threaded Tab with a button head screw.
- Attaches to the wood end post by installing a Lag Eye into a pre-drilled hole in the end post and attaching the Fixed Jaw to the Lag Eye with a button head screw (lag eye and screw information on page 5).
- Cable is retained within the body portion of the fitting by a ferrule-swaged on the end of the cable, which must be purchased separately (see ferrule information on page 7).
- Lock Nut is installed all the way onto the Threaded Jaw first followed by the body, which is secured onto the jaw, creating tension on the cable.
- Once sufficient tension is achieved the Lock Nut is secured against the end of the body to secure the fitting from loosening.

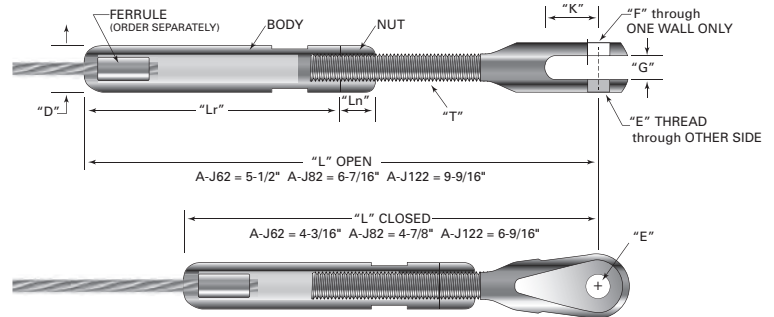

Alternate design option see Page 8

While this fitting can be used on pitched or level runs, it's most appropriate for pitched runs because the Fixed Jaw pivots at the tab (for metal) and at the Lag Eye (for wood). The pre-drilled hole for the Lag Eye is drilled level, making installation easy.

TYPE 316 STAINLESS STEEL

CABLE DIA.	PART NO.	USE WITH FERRULE	WOOD		METAL		"D" DIA.	"E" THREAD	"F" DIA.	"G"	"K"	"Ln"	"Lr"	"T" THREAD
			USE WITH SCREW NO.	USE WITH LAG EYE	USE WITH TAB NO.									
1/8"	A-J62	F-4	SC-6	LE-6	TT-6B	.490"	1/4-28	.260"	.260"	.56"	.375"	2.75"	5/16-24 LH	
3/16"		F-6												
1/4"	A-J82	F-8	SC-8	LE-8	TT-8B	.617"	3/8-24	.390"	.313"	.75"	.500"	3.00"	7/16-20 LH	
5/16"	A-J122	F-10	SC-8	LE-8	TT-8B	.744"	3/8-24	.390"	.348"	.87"	.620"	4.50"	9/16-18	
3/8"		F-12												

Invisiware® Threaded Tab

Stainless steel threaded tabs are used to mount an Adjust-a-Jaw®, Adjust-a-Body®, Fixed Jaw, Clip on Jaw, or Push-Lock® with Threaded Eye onto a metal post.

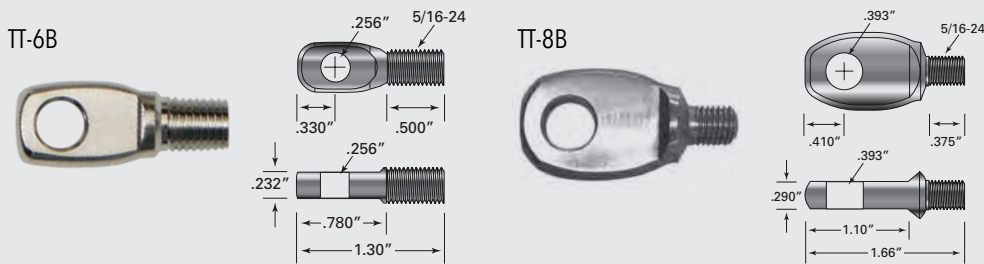

TYPE 316 STAINLESS STEEL

CABLE DIA.	PART NO.
1/8", 3/16"	TT-6B
1/4", 5/16", 3/8"	TT-8B

Lag Eye and Extended Length Lag Eye

A convenient, easy-to-install means for attaching an Adjust-A-Jaw® or Fixed Jaw to a wood post.

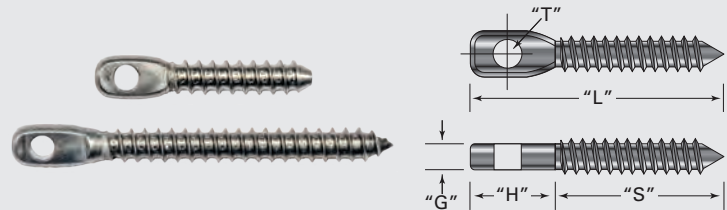

TYPE 316 STAINLESS STEEL

CABLE DIA.	PART NO.	"G"	"H"	"T"	"S"	"L"	MIN. NOMINAL TIMBER SIZE
1/8"	LE-6	.232"	.735"	.256"	1.50"	2.23"	4x4
3/16"							
1/4"	LE-8	.290"	1.20"	.393"	2.00"	3.55"	4x4
5/16"							
3/8"							

Extended Length Lag Eyes with 3-inch Thread

TYPE 316 STAINLESS STEEL

CABLE DIA.	PART NO.	"G"	"H"	"T"	"S"	"L"	MIN. NOMINAL TIMBER SIZE
1/8"	LE-6L	.232"	.780"	.256"	3.00"	3.94"	4x4
3/16"							

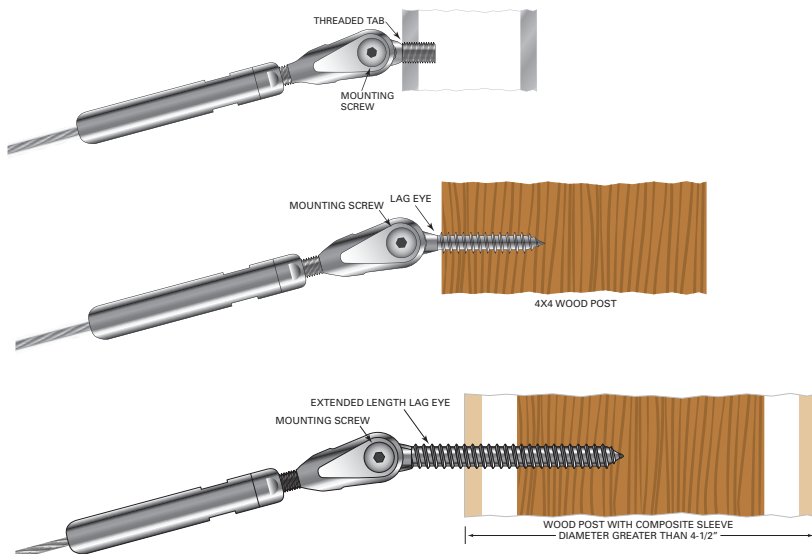

Mounting Screw

Stainless steel socket-head screws for mounting an Adjust-A-Jaw® or Fixed Jaw to a wood or metal post.



TYPE 316 STAINLESS STEEL

CABLE DIA.	PART NO.	THREAD
1/8", 3/16"	SC-6	1/4-28
1/4", 5/16", 3/8"	SC-8	3/8-24

Adjust-A-Body® with Hanger Bolt



Swaged, tensioning, face-of-the-post-mounted fitting recommended for level runs only. This fitting is available for 1/8", 3/16", and 1/4" diameter 1x19 stainless steel cable.

- Can be used with any fitting on the opposite end of the run. The Lag Thread of the Hanger Bolt portion of the fitting is driven into a pre-drilled hole in the wood end post.
- Cable is retained within the body portion of the fitting by a ferrule swaged onto the end of the cable.
- Lock Nut is installed all the way onto the Hanger Bolt first followed by the body, which is secured onto the Hanger Bolt, creating tension on the cable.
- Once sufficient tension is achieved the Lock Nut is secured against the end of the body to prevent the fitting from loosening.

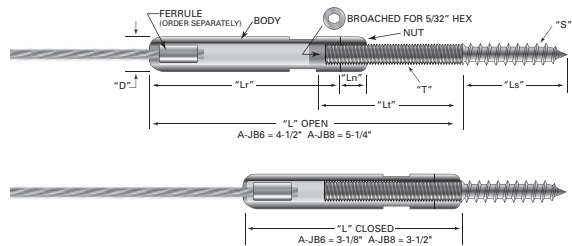
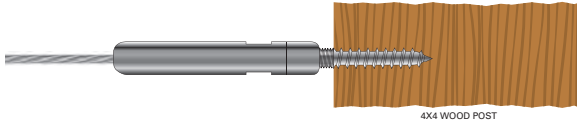

Adjust-A-Body® with Extended Length Hanger Bolt



Fitting is identical to the Adjust-a-Body® with Hanger Bolt (shown at left) except it's used for sleeved posts with an outside diameter of greater than 4-1/2". The extended length Hanger Bolt is 3" long, designed to reach past sleeves and drywall to find the wood post or frame underneath.

Use of this fitting requires an appropriately sized ferrule that is swaged onto the cable, which must be purchased separately (see information below).

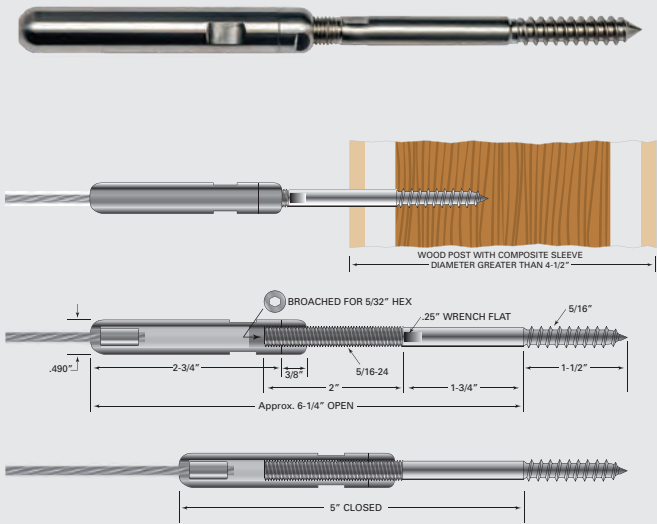

TYPE 316 STAINLESS STEEL

CABLE DIA.	PART NO.	USE WITH FERRULE NO.
1/8"	A-JB6-L	F-4
3/16"		F-6

TYPE 316 STAINLESS STEEL

CABLE DIA.	PART NO.	USE WITH FERRULE NO.	"S"	"T" THREAD	"Ls"	"Lt"	"Ln"	"Lr"	"D" DIA.	MINIMUM TIMBER SIZE
1/8"	A-JB6	F-4	5/16"	5/16-24 LH	1.50"	2.00"	.375"	2.75"	.490"	4 x 4
3/16"	A-JB6	F-6	5/16"	5/16-24 LH	1.50"	2.00"	.375"	2.75"	.490"	
1/4"	A-JB8	F-8	7/16"	7/16-20 LH	2.00"	2.50"	.500"	3.00"	.617"	

Adjust-A-Body® with Threaded Bolt

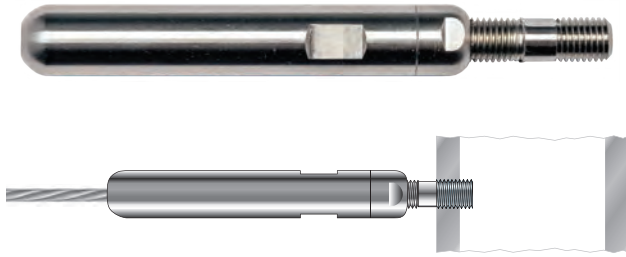

Exposed, swaged, tensioning, face-of-the-post-mounted fitting recommended for level runs only. This fitting is available for 1/8", 3/16", 1/4", 5/16", and 3/8" diameter 1x19 stainless steel cable.

- Can be used with any fitting on the opposite end of the run.
- The Threaded Bolt portion of the fitting is secured into a pre-drilled and tapped hole in the end post.
- Cable is retained within the body portion of the fitting by a ferrule swaged onto the end of the cable.
- Lock Nut is installed all the way onto the Threaded Bolt first followed by the body, which is secured onto the threaded bolt, creating tension on the cable.
- Once sufficient tension is achieved the Lock Nut is secured against the end of the body to secure the fitting from loosening.
- Use of this fitting requires an appropriately sized ferrule that is swaged onto the cable, which must be purchased separately (see ferrule information here on page 7).

Ferrule

The ferrule is used to retain an Adjust-A-Jaw®, Adjust-A-Body® or a Fixed Jaw onto cable.



Photo of ferrule before swaging.

TYPE 316 STAINLESS STEEL

CABLE DIA.	PART NO.	AFTER SWAGED "D" DIA.	"L" LENGTH
1/8"	F-4	.250"	.61"
3/16"	F-6	.250"	.56"
1/4"	F-8	.375"	.70"
5/16"	F-10	.500"	.73"
3/8"	F-12	.500"	.71"

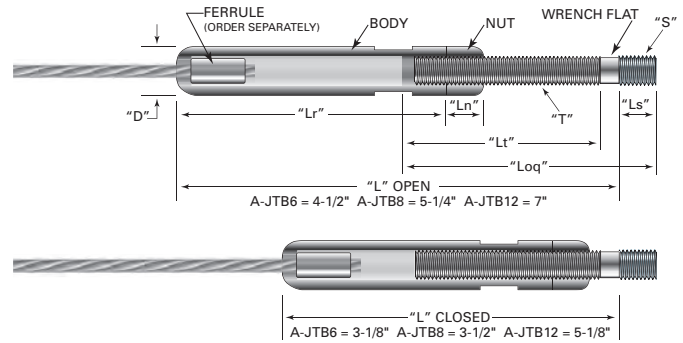

TYPE 316 STAINLESS STEEL

CABLE DIA.	PART NO.	USE WITH FERRULE NO.	"S"	"T" THREAD	"Ls"	"Lt"	"Loq"	"Ln"	"Lr"	"D"
1/8"	A-JTB6	F-4	5/16-24	5/16-24 L.H.	.375"	2.00"	2.625"	.375"	2.75"	.490"
3/16"		F-6								
1/4"	A-JTB8	F-8	5/16-24	7/16-20 L.H.	.375"	2.50"	3.125"	.500"	3.00"	.617"
5/16"	A-JTB12	F-10	1/2-20	9/16-18	.62"	3.00"	4.00"	.62"	4.50"	.744"
3/8"		F-12								

Adjust-A-Body® with Clevis

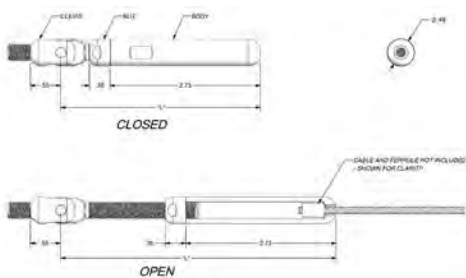
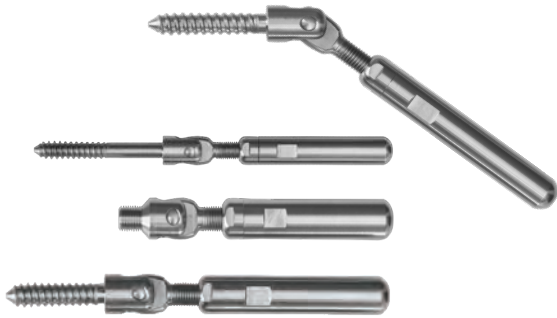

Exposed, swaged, tensioning, face-of-the-post-mounted fitting suitable for level or pitched runs and is available for 1/8" and 3/16" diameter 1x19 stainless steel cable.

- Can be used with any fitting on the opposite end of the run.
- Consists of two separate pieces: the articulating Threaded Bolt and Adjust-a-Body® tensioning body.
- Threaded Clevis is installed into a pre-drilled or tapped hole in the end post.
- Cable is retained within the body portion of the fitting by a ferrule swaged onto the end of the cable.
- Use of this fitting requires an appropriate sized ferrule that is swaged onto the cable, which must be purchased separately (see ferrule information on page 7).
- Once sufficient tension is achieved the Lock Nut is secured against the end of the body to secure the fitting from loosening.

Alternate swaged design see page 8

Alternate swageless design see page 14

CABLE DIA.	PART NO.	USE WITH FERRULE NO.	"T" THREAD	"Lt"	"Ln"	"Lr"	"D" DIA.
1/8"	METAL: A-J6-CL-M WOOD: A-J6-CL-W COMP: A-J6-CL-C	F-4	5/16-24 LH	2.00"	.375"	2.73"	.490"
3/16"		F-6					



Adjust-A-Body® with Toggle

Exposed, swaged, tensioning, face-of-the-post-mounted fitting for use on level runs only. This fitting is **ONLY** available for 1/8" diameter 1x19 stainless steel cable.

- Can be used with any fitting on the opposite end of the run.
- The Toggle portion of the fitting is secured into a pre-drilled hole in the end post. No tapping required!
- Cable is retained within the body portion of the fitting by a ferrule swaged onto the end of the cable.

- Lock Nut is installed all the way onto the Toggle first followed by the body, which is secured onto the Toggle, creating tension on the cable.
- Once sufficient tension is achieved the Lock Nut is secured against the end of the body to secure the fitting from loosening.
- Use of this fitting requires an appropriately sized ferrule that is swaged onto the cable, which must be purchased separately. Note: Minimum hole diameter of 5/16 and a minimum post thickness of 1/4" is required.

Order #: A-J6-T2-4

CABLE DIA.	PART NO.
1/8"	A-J6-T2-4

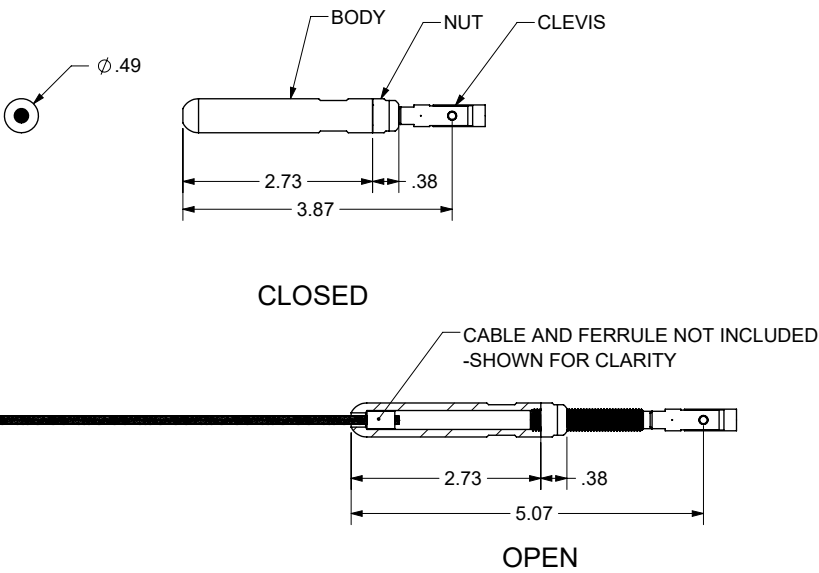

SWAGED FITTINGS - TENSIONERS



SWAGED NON-TENSIONING FITTINGS

HARDWARE FOR METAL POSTS

- Invisiware® Radius Ferrule
- Invisiware® Stud
- Fixed Jaw and Clip-On Fixed Jaw

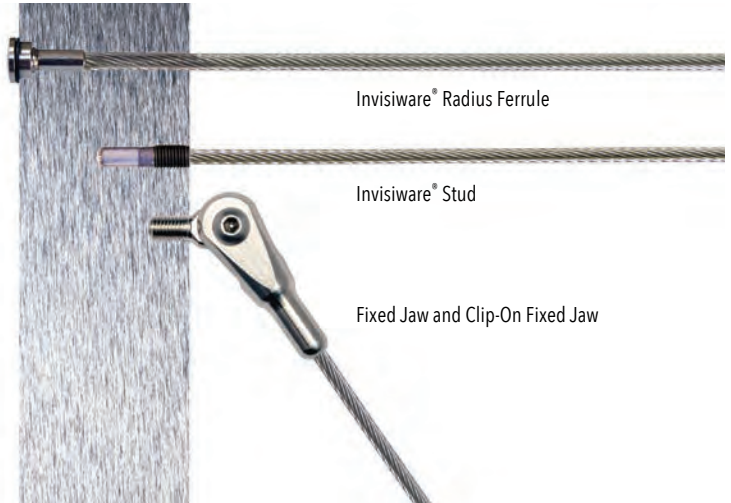

HARDWARE FOR WOOD POSTS & WOOD POSTS WITH SLEEVES

- Invisiware® Radius Ferrule
- Fixed Jaw and Clip-On Fixed Jaw

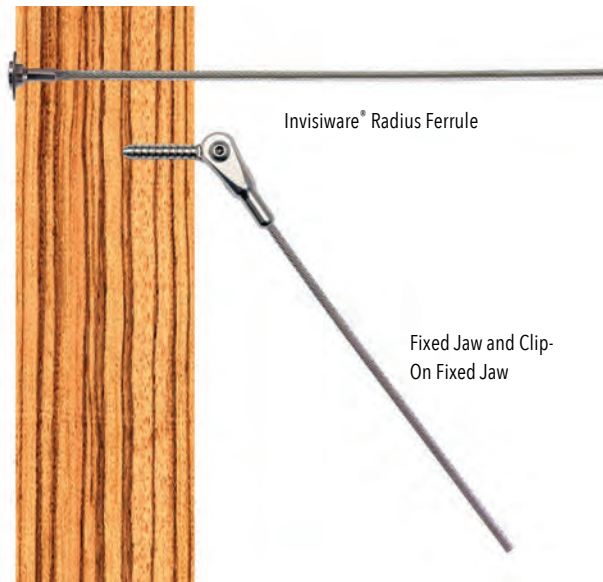

SWAGING REQUIRED: These fittings must be attached with swaging equipment capable of developing proper force based on the fittings' mass. Special equipment is required.



NON-TENSIONING FITTING: A fitting with this symbol is a non-tensioning fitting. Only one (1) non-tensioning fitting can be used on a cable run to be properly installed.

Economical Through-the-Post Fitting Option

Invisiware® Radius Ferrule



Concealed, swaged, non-tensioning, through-the-post-mounted fitting suitable for pitched or level runs. Fitting is available for 1/8", 3/16", 1/4", 5/16", and 3/8" diameter 1x19 stainless steel cable.

- Must be used with a tensioning fitting on the opposite end of the run.
- Head shaped to appear like the Invisiware® Receiver from the outside of the post (like the Invisiware® Receiver, this fitting is concealed within the post).
- Whenever practical, use this part on one end of your cable run and an Invisiware® Receiver with a stud on the opposite end.
- Installs into a pre-drilled hole drilled through the face of the post (to accommodate the cable at minimum) and a pre-drilled hole through the back side of the post to accommodate the fitting (see our Hardware Mounting / Hole Boring Guide).
- You should have 2" of clearance on the back side of your end post (the cable would likely be attached to the Radius Ferrule prior to installing it through the back side of the post).
- Furnished with a Delrin® washer or flat washer to install between the shoulder of the fitting and the end post to protect the surface of the finish of the end post as tension is applied.

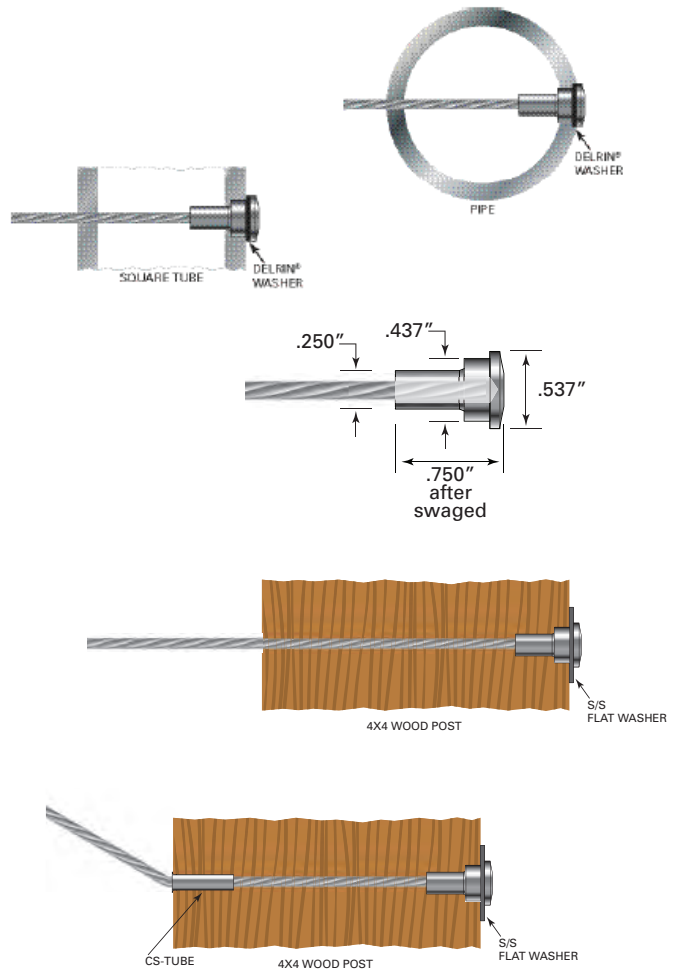

TYPE 316 STAINLESS STEEL

CABLE DIA.	PART NO.	"D" DIA. AFTER SWAGED	"L" LENGTH AFTER SWAGED	"S" HEAD DIA.	"A" SHOULDER DIA.
1/8"	RF-4	.250"	.750"	.537"	.437"
3/16"	RF-6	.250"	.750"	.537"	.437"
1/4"	RF-8	.375"	1.000"	.646"	.531"
5/16"	RF-10	.500"	1.000"	.865"	.687"
3/8"	RF-12	.500"	1.000"	.865"	.687"



Invisiware® Stud

Concealed, swaged, non-tensioning, inside-the-post-mounted fitting that is suitable for use on level or pitched runs and is available for 1/8", 3/16", 1/4", 5/16", and 3/8" diameter 1x19 stainless steel cable.

The Invisiware® Stud can be used as a non-tensioning end in level or pitched applications. It is swaged onto one end of the cable and threaded into a drilled and tapped hole in the face of the post (1/4" wall thickness minimum).

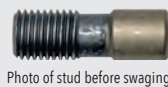
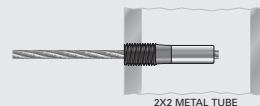
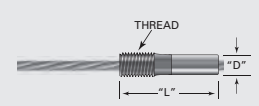

Photo of stud before swaging.



2X2 METAL TUBE



TYPE 316 STAINLESS STEEL — MOLY COATED

CABLE DIA.	PART NO.	THREAD	"L"	"D" DIAMETER AFTER SWAGED
1/8"	S-4-TC	5/16-24	1.180"	.250"
3/16"	S-6-TC	5/16-24	1.140"	.250"
1/4"	S-8	7/16-20	1.380"	.375"
5/16"	S-10	9/16-18	1.330"	.500"
3/8"	S-12	9/16-18	1.310"	.500"

Fixed Jaw and Threaded Tab OR Lag Eye



Exposed, swaged, non-tensioning, face-of-the-post-mounted fitting suitable for use on level or pitched runs and is available for 1/8", 3/16", 1/4", 5/16", and 3/8" diameter 1x19 stainless steel cable.

- Must be used with a tensioning fitting on the opposite end of the run. Attaches to the metal end post by installing a Threaded Tab into a pre-drilled tapped hole in the end post and attaching the Fixed Jaw to the Threaded Tab with a button head screw.
- Attaches to the wood end post by installing a Lag Eye into a pre-drilled hole in the end post and attaching the Fixed Jaw to the Lag Eye with a button head screw (lag eye and screw information on page 5).
- Cable is retained within the Fixed Jaw fitting by a ferrule swaged onto the end of the cable (see page 7).
- Screw and Threaded Tab are **sold separately** (screw and threaded tab information on pages 5).

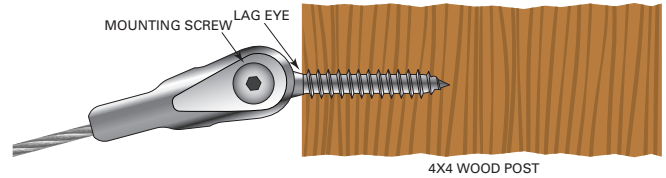
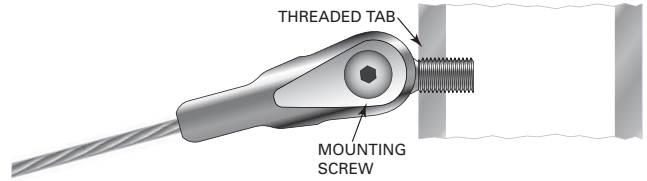

While this fitting can be used on pitched or level runs, it's most appropriate for pitched runs because the Fixed Jaw pivots at the tab (for metal) and at the Lag Eye (for wood). The pre-drilled hole for the Lag Eye is drilled level, making installation easy.

This fitting was designed to be compatible in appearance to the Adjust-A-Jaw[®] tensioning fitting.

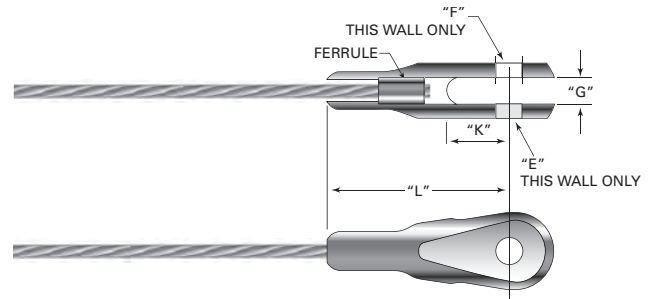

TYPE 316 STAINLESS STEEL

CABLE DIA.	PART NO.	USE WITH FERRULE NO.	WOOD		METAL		"E" THREAD	"F" DIA.	"G"	"K"	"L"
			USE WITH SCREW NO.	USE WITH LAG EYE NO.	USE WITH TAB NO.						
1/8"	F-J62	F-4	SC-6	LE-6	TT-6B	1/4-28	.260"	.260"	.56"	1.75"	
3/16"	F-J62	F-6	SC-6	LE-6	TT-6B	1/4-28	.260"	.260"	.56"	1.75"	
1/4"	F-J82	F-8	SC-8	LE-8	TT-8B	3/8-24	.390"	.313"	.75"	2.12"	
5/16"	F-J122	F-10	SC-8	LE-8	TT-8B	3/8-24	.390"	.348"	.87"	2.25"	
3/8"	F-J122	F-12	SC-8	LE-8	TT-8B	3/8-24	.390"	.348"	.87"	2.25"	

Clip-On Fixed Jaw and Threaded Tab OR Lag Eye



The Clip-On Fixed Jaw is externally a duplicate of the Fixed Jaw and is only available for 1/8" and 3/16" diameter 1x19 stainless steel cable.

- For applications that call for factory swaged fittings on both ends of the cable, without requiring over-sized holes through the intermediate posts (so an entire Fixed Jaw could pass through).
- Fitting accomplishes this with a maximum diameter of a .250" diameter ferrule that is pre-swaged to the cable.
- Run the cable with only a ferrule swaged to it through the intermediate posts, then to the end post to which it will attach.
- Slip the jaw onto the cable over the ferrule and the clip installed at the ferrule.
- Jaw then slides back against the clip, which prevents the fitting from coming off the cable.
- Attaches to a metal end post by installing a Threaded Tab into a pre-drilled and tapped hole and attaching the Clip-On Fixed Jaw to the Threaded Tab with a button head screw (screw and threaded tab information on pages 5).

- Attaches to the wood end post by installing a Lag Eye into a pre-drilled hole and attaching the Clip-On Fixed Jaw to the Lag Eye with a button head screw. Lag Eye and screw sold separately (see lag eye and screw information on page 5).

Use of this fitting requires an appropriately sized ferrule that is swaged onto the cable, which must also be purchased separately (ferrule information on page 7).

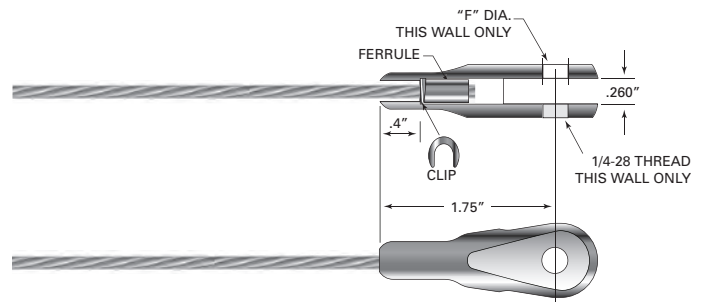

TYPE 316 STAINLESS STEEL

CABLE DIA.	PART NO.	WOOD			METAL				
		USE WITH FERRULE NO.	USE WITH LAG EYE NO.	USE WITH SCREW NO.	USE WITH TAB NO.	"F" DIA.	"G"	"K"	"L"
1/8"	F-JC2-4	F-4	LE-6	SC-6	TT-6B	.260"	.260"	.56"	1.75"
3/16"	F-JC2-6	F-6	LE-6	SC-6	TT-6B	.260"	.260"	.56"	1.75"

Reference Fixed Jaw schematic above for call-outs.



SWAGELESS TENSIONING FITTINGS

HARDWARE FOR METAL POSTS

- Invisiware® Receiver with Push-Lock® Stud
- Push-Lock® Tensioner with Threaded Bolt
- Push-Lock® Turnbuckle Threaded Bolt
- Push-Lock® Tensioner with Threaded Clevis
- Push-Lock® Tensioner with Toggle

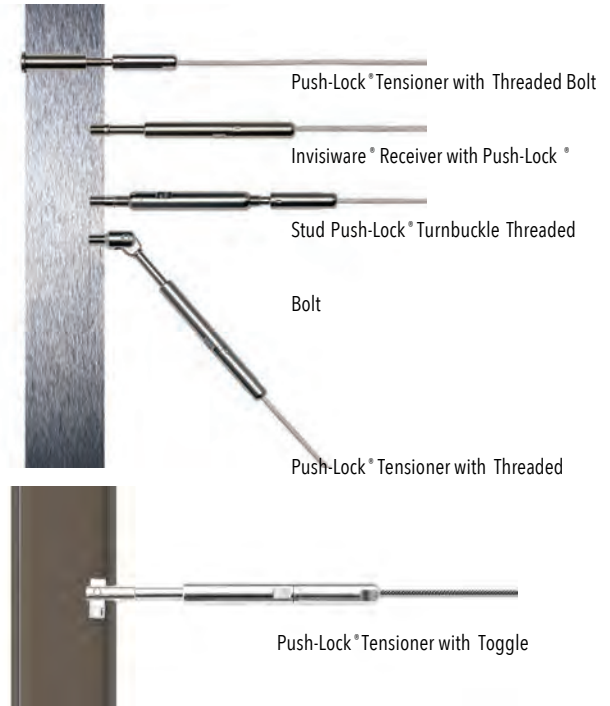

HARDWARE FOR WOOD POSTS & WOOD POSTS WITH SLEEVES

- Invisiware® Receiver with Push-Lock® Stud
- Push-Lock® Tensioner with Hanger Bolt
- Push-Lock® Turnbuckle Hanger Bolt
- Push-Lock® Tensioner with Lag Clevis

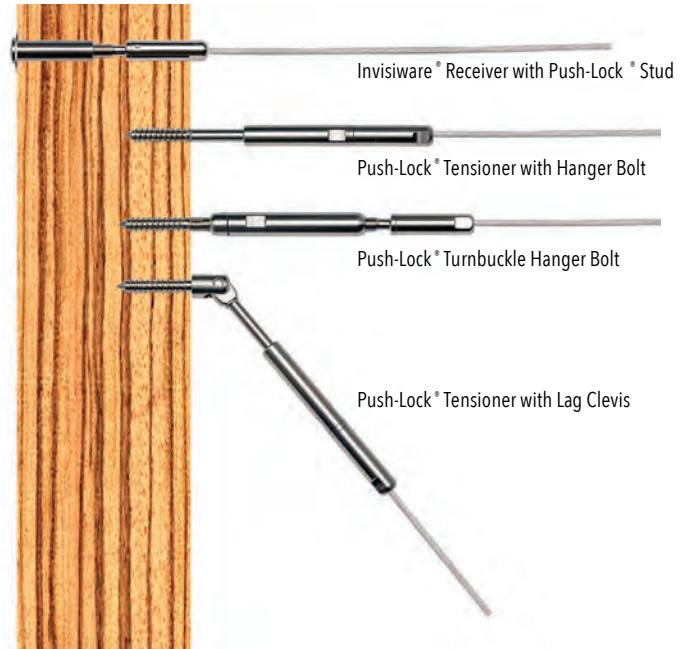

SWAGING REQUIRED: These fittings must be attached with swaging equipment capable of developing proper force based on the fittings' mass. Special equipment is required.



NON-TENSIONING FITTING: A fitting with this symbol is a non-tensioning fitting. Only one (1) non-tensioning fitting can be used on a cable run to be properly installed.

Invisiware® Receiver with Push-Lock® Stud



The Invisiware® Receiver with Push-Lock® Stud combination is an exposed, swageless, tensioning, through-the-post-mounted fitting suitable for level runs only, and is available for 1/8" and 3/16" diameter 1x19 stainless steel cable.

- Can be used with any fitting on the opposite end of the run.
- Fitting requires a minimum of 2-1/2" of clearance exists on the back side of the end post to install the Receiver into the post.
- Receiver is furnished with a Delrin® washer to install between the shoulder of the fitting and the end post to protect the surface of the finish of the post as tension is applied.
- Cable attaches to the Push-Lock® Stud fitting via our locking wedge system which requires no special tools.

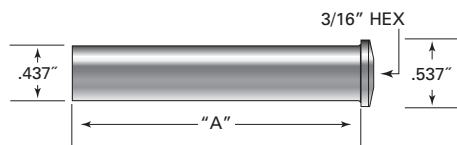
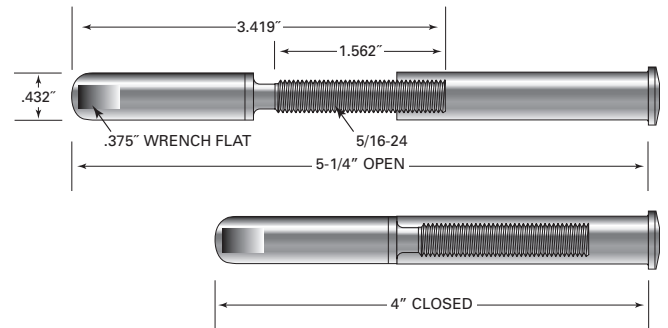
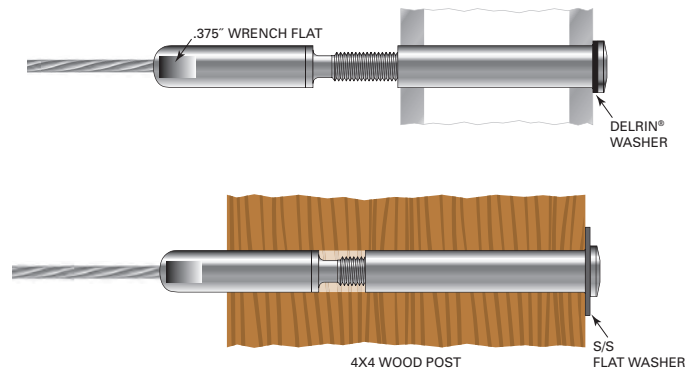

TYPE 316 STAINLESS STEEL

CABLE DIA.	USE WITH SWAGELESS STUD NO.	A = LENGTH OF RECEIVER BODY				
		2.30"	2.40"	2.53"	3.03"	3.56"
1/8"	PLST-4	R-6-42	R-6-72	R-6-82	R-6-52	R-6-62
3/16"	PLST-6					

Push-Lock® Stud



The Push-Lock® Stud attaches manually with no special tools required. The cable attaches to the fitting via our Push-Lock® locking wedge system.

CABLE DIA.	PART NO.
1/8"	PLST-4
3/16"	PLST-6

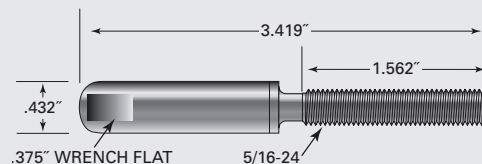

We do not recommend this fitting being installed in pitched applications because it would require drilling all of the holes in the end post at an angle. While this is possible with special fixtures, if it is not done correctly the end result would be visually unacceptable.

Push-Lock® Tensioner with Threaded Bolt

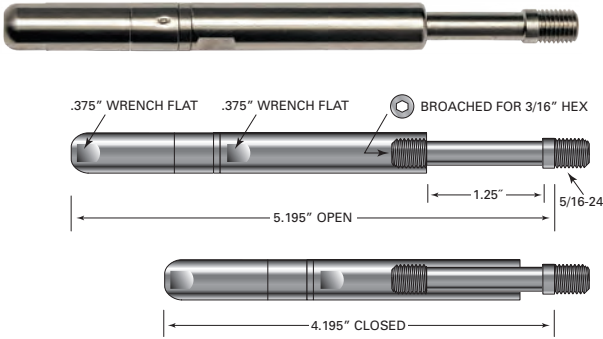

Exposed, swageless, tensioning, face-of-the-post-mounted fitting suitable for use on level runs only, and is available for 1/8" and 3/16" diameter 1x19 stainless steel cable.

- Can be used with any fitting on the opposite end of the run.
- Consists of two separate pieces: the Threaded Bolt and the Push-Lock® tensioning body.
- Threaded Bolt is installed into a pre-drilled and tapped hole in the end post.
- Cable attaches to the fitting via our Push-Lock® locking wedge system which requires no special tools.
- Body threads onto the other end of the bolt, connecting the two pieces.
- Tension is created by securing the post-side segment of the body onto the machine threads while preventing the cable-side segment of the body from turning.

CABLE DIA.	PART NO.
1/8"	PL-SFC-MS-4
3/16"	PL-SFC-MS-6

Push-Lock® Tensioner with Threaded Clevis

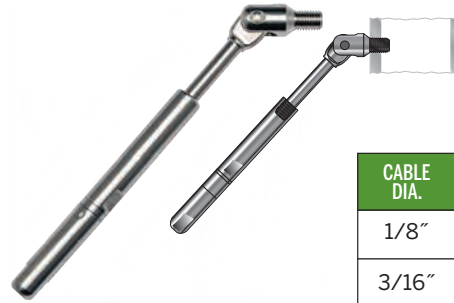

CABLE DIA.	PART NO.
1/8"	PL-SFC-MP-4
3/16"	PL-SFC-MP-6

Exposed, swageless, tensioning, face-of-the-post-mounted fitting suitable for level or pitched runs, and is available for 1/8" and 3/16" diameter 1x19 stainless steel cable.

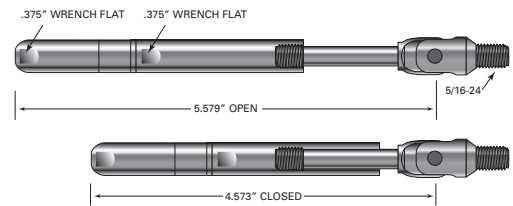

- Can be used with any fitting on the opposite end of the run
- Consists of two separate pieces: the articulating Threaded Bolt and Push-Lock® tensioning body.
- Threaded Clevis is installed into a pre-drilled and tapped hole in the end post.
- Cable attaches to the body via our Push-Lock® locking wedge system which requires no special tools.
- Machine thread on the articulating bolt threads into the body, connecting the two pieces.
- Tension is created by securing the post-side segment of the body onto the machine threads while preventing the cable-side segment of the body from turning.

Push-Lock® Turnbuckle Threaded Bolt



Exposed, swageless, tensioning, face-of-the-post-mounted fitting suitable for level runs only, and is available for 1/8" and 3/16" diameter 1x19 stainless steel cable.

- Can be used with any fitting on the opposite end of the run
- Consists of four separate pieces: the Threaded Bolt, the body, the Lock Nut, and the Push-Lock® Stud.
- Most common application for this fitting is when substantial take-up is required AND there is a preference for a swageless fitting, AND there is less than 2-1/2" of space available in back of the end post.

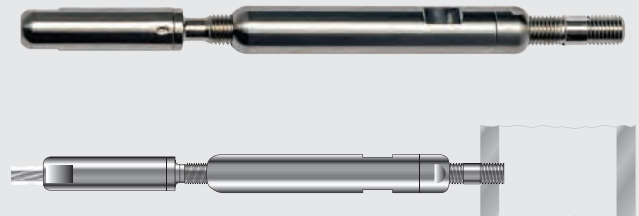

CABLE DIA.	PART NO.
1/8"	PL-TB-TB-4
3/16"	PL-TB-TB-6

Push-Lock® Tensioner with Hanger Bolt



Exposed, swageless, tensioning, face-of-the-post-mounted fitting suitable for level runs only, and is available for 1/8" and 3/16" diameter 1x19 stainless steel cable.

- Can be used with any fitting on the opposite end of the run. This fitting consists of two separate pieces: the Hanger Bolt and Push-Lock® tensioning body.
- The Hanger Bolt is driven into a pre-drilled hole in the face of the wood end post. The cable attaches to the body via our Push-Lock® locking wedge system, which requires no special tools. The machine thread of the Hanger Bolt threads into the body, connecting the two pieces.
- Tension is created by securing the post-side segment of the body onto the machine threads while preventing the cable-side segment of the body from turning.
- The Push-Lock® Tensioner with Hanger Bolt can be used with sleeved posts as well.

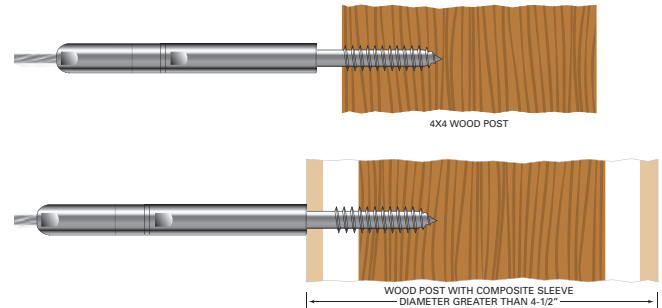
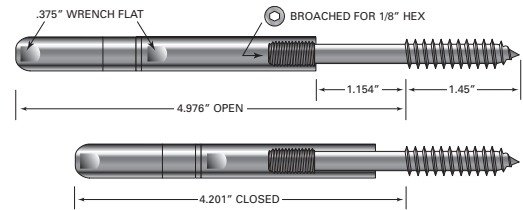

CABLE DIA.	PART NO.
1/8"	PL-SFC-WS-4
3/16"	PL-SFC-WS-6

We do not recommend installing this fitting in pitched applications because it would require drilling all of the holes in the end post at an angle. While this is possible with special fixtures, if it is not done correctly the end result would be visually unacceptable.

Push-Lock® Tensioner with Lag Clevis



Exposed, swageless, tensioning, face-of-the-post-mounted fitting that is suitable for level or pitched runs, and is available for 1/8" and 3/16" diameter 1x19 stainless steel cable.

- Can be used with any fitting on the opposite end of the run.
- Consists of two separate pieces: the articulating Lag Clevis and the Push-Lock® tensioning body.
- Cable attaches to the body via our Push-Lock® locking wedge system, which requires no special tools. The machine thread of the articulating lag threads into the body, connecting the two pieces.
- Lag Clevis is driven into a pre-drilled hole in the wood end post.
- Tension is created by securing the post-side segment of the body onto the machine threads while preventing the cable-side segment of the body from turning.

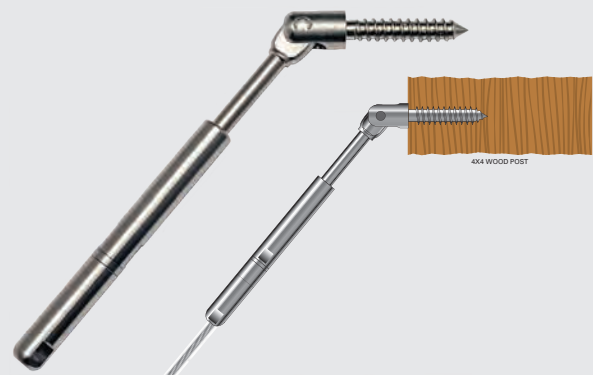

CABLE DIA.	PART NO.
1/8"	PL-SFC-WP-4-1
3/16"	PL-SFC-WP-6-1

Push-Lock® Tensioner with Toggle



Exposed, swageless, tensioning, face-of-the-post-mounted fitting suitable for use on level runs and is only available for 1/8" diameter 1x19 stainless steel cable.

- Can be used with any fitting on the opposite end of the run.
- Consists of two separate pieces: the Toggle and the Push-Lock® tensioning body.
- Toggle is installed into a pre-drilled hole in the end post. No tapping required!
- Cable attaches to the fitting via our Push-Lock® locking wedge system which requires no special tools.
- Body threads onto the other end of the Toggle, connecting the two pieces.
- Tension is created by securing the post-side segment of the body onto the toggle side while preventing the cable-side segment of the body from turning.

Order #: PL-CT-4

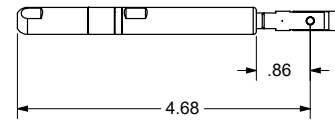
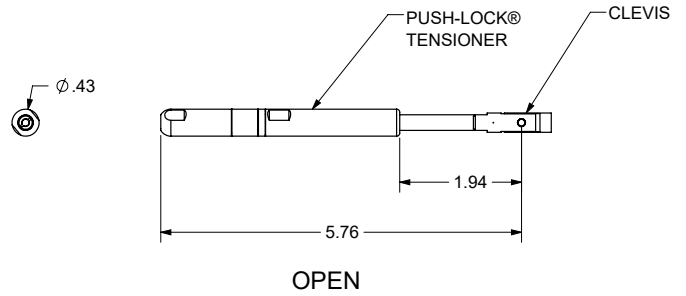

CABLE DIA.	PART NO.
1/8"	PL-CT-4

We do not recommend installing this fitting in pitched applications because it would require drilling all of the holes in the end post at an angle. While this is possible with special fixtures, if it is not done correctly the end result would be visually unacceptable. Note: Minimum hole diameter of 5/16 and a minimum post thickness of 1/4" is required.



SWAGELESS NON-TENSIONING FITTINGS

HARDWARE FOR METAL POSTS

- Push-Lock®
- Push-Lock® Threaded Bolt
- Push-Lock® Threaded Clevis
- Pull-Lock®
- Push-Lock® Toggle

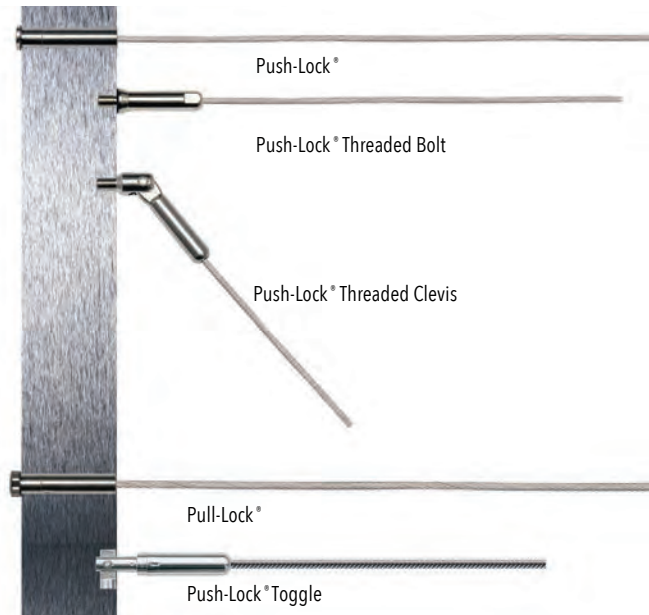

HARDWARE FOR WOOD POSTS & WOOD POSTS WITH SLEEVES

- Push-Lock®
- Push-Lock® Lag
- Push-Lock® with Lag Clevis
- Pull-Lock®

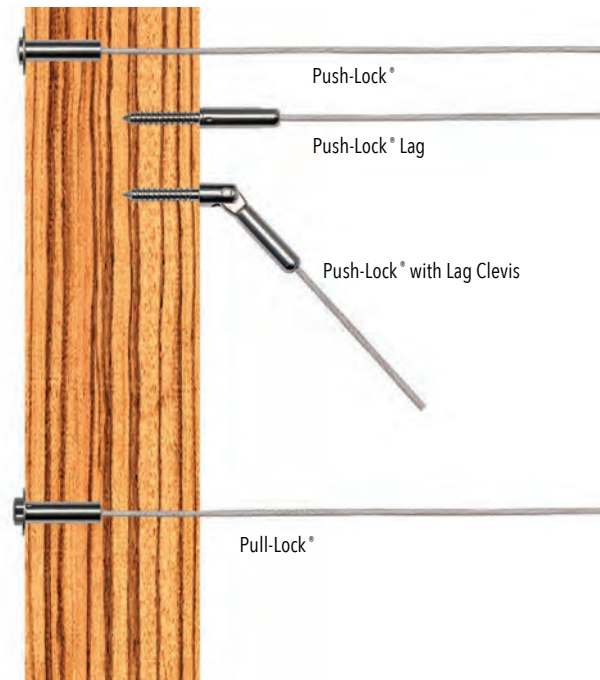

SWAGING REQUIRED: These fittings must be attached with swaging equipment capable of developing proper force based on the fittings' mass. Special equipment is required.



NON-TENSIONING FITTING: A fitting with this symbol is a non-tensioning fitting. Only one (1) non-tensioning fitting can be used on a cable run to be properly installed.

Push-Lock®

Concealed, swageless, non-tensioning, through-the-post-mounted fitting suitable for use on level runs only, and is available for 1/8" and 3/16" diameter 1x19 stainless steel cable.

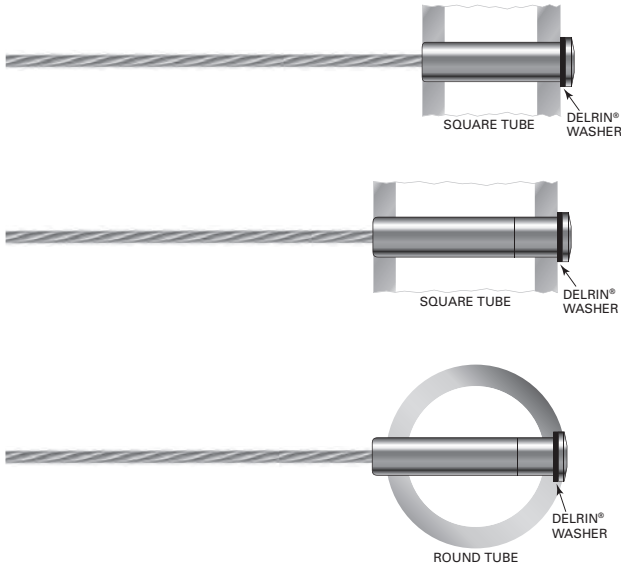
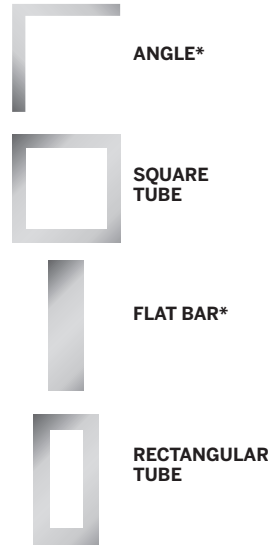
FLAT SIDED FRAME "F"

* Push-Locks cannot be used with angle shapes or flat bar in pitch applications unless the post hole is drilled at the angle of the stair rake and a beveled washer is used.

ROUND TUBE FRAME "R"

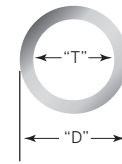
PIPE FRAME "P"

"T" = Theor. I.D. (Pipe Size)
 "D" = Outside diameter

SIZE	"T"	"D"
1-1/4"	1.25"	1.66"
1-1/2"	1.50"	1.91"
2"	2.00"	2.375"

- Must be used with a tensioning fitting on the opposite end of the run.
- Fitting is installed into a pre-drilled hole in the end post.
- Requires enough clearance on the back side of the end post (to install the fitting through the back side of the post) and that amount of clearance depends on the length of the Push-Lock® fitting chosen.
- Furnished with a Delrin® washer or flat washer to install between the shoulder of the fitting and the end post to protect the surface of the finish as tension is applied
- Recommended: choose a length of Push-Lock® that is the same as the cross section dimension of the end post.
- Cable attaches to the fitting via our Push-Lock® locking wedge system which requires no special tools.
- Fitting is designed to look similar to the Invisiware® Receiver from the exterior of the post, and is recommended to use a Receiver with stud on the opposite end, whenever practical, to maintain a consistent look.

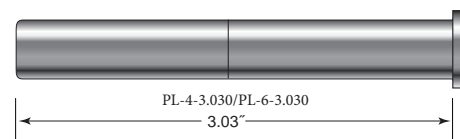
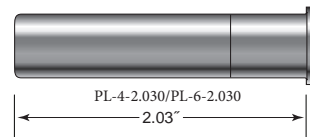
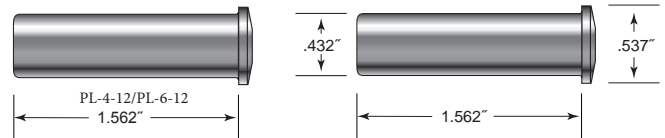
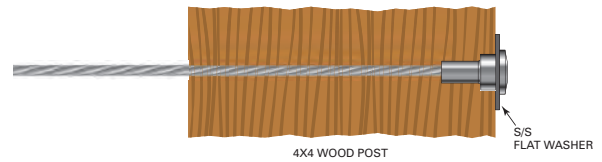
METAL FRAMING OPTIONS FOR PUSH-LOCK® FITTINGS

1/8" CABLE PART NO.	3/16" CABLE PART NO.	FRAME "F"	FRAME "R"	FRAME "P"	"L" LENGTH
PL-4-12	PL-6-12	1-1/2"	1-1/2"	1-1/4"	1.562"
PL-4-2.030	PL-6-2.030	2"	2"	1-1/2"†	2.030"
PL-4-3.030	PL-6-3.030	3"	3"	N/A	3.030"
PL-4	PL-6	4"x4"	N/A	N/A	1.562"

† Will protrude from cable side of post +/- .125".

Push-Lock® Threaded Bolt

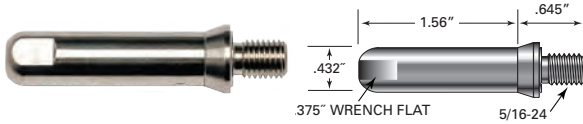

Exposed, swageless, non-tensioning, face-of-the-post-mounted fitting suitable for use on level runs only, and is available for 1/8" and 3/16" diameter 1x19 stainless steel cable.

- Must be used with a tensioning fitting on the opposite end of the run.
- Fitting is installed into a pre-drilled and tapped hole.
- Furnished with a Delrin® washer to install between the shoulder of the fitting and the end post to protect the surface of the finish as the fitting is installed.
- Cable attaches to the fitting via our Push-Lock® locking wedge system which requires no special tools.



CABLE DIA.	PART NO.
1/8"	PL-FM-MS-4
3/16"	PL-FM-MS-6

Push-Lock® Threaded Clevis



Exposed, swageless, face-of-the-post-mounted fitting suitable for level or pitched runs, and is available for 1/8" and 3/16" diameter 1x19 stainless steel cable.

- Can be used with any tensioning fitting on the opposite end of the run.
- Fitting is installed into a pre-drilled and tapped hole in the end post.
- Cable attaches to the body via our Push-Lock® locking wedge system which requires no special tools.

While this fitting can be used on pitched or level runs, it's most appropriate for pitched runs because the body of the fitting pivots at the clevis.

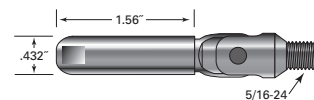
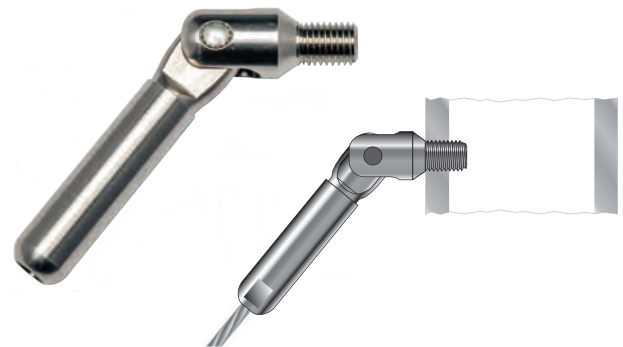

CABLE DIA.	PART NO.
1/8"	PL-CL-RP-4
3/16"	PL-CL-RP-6

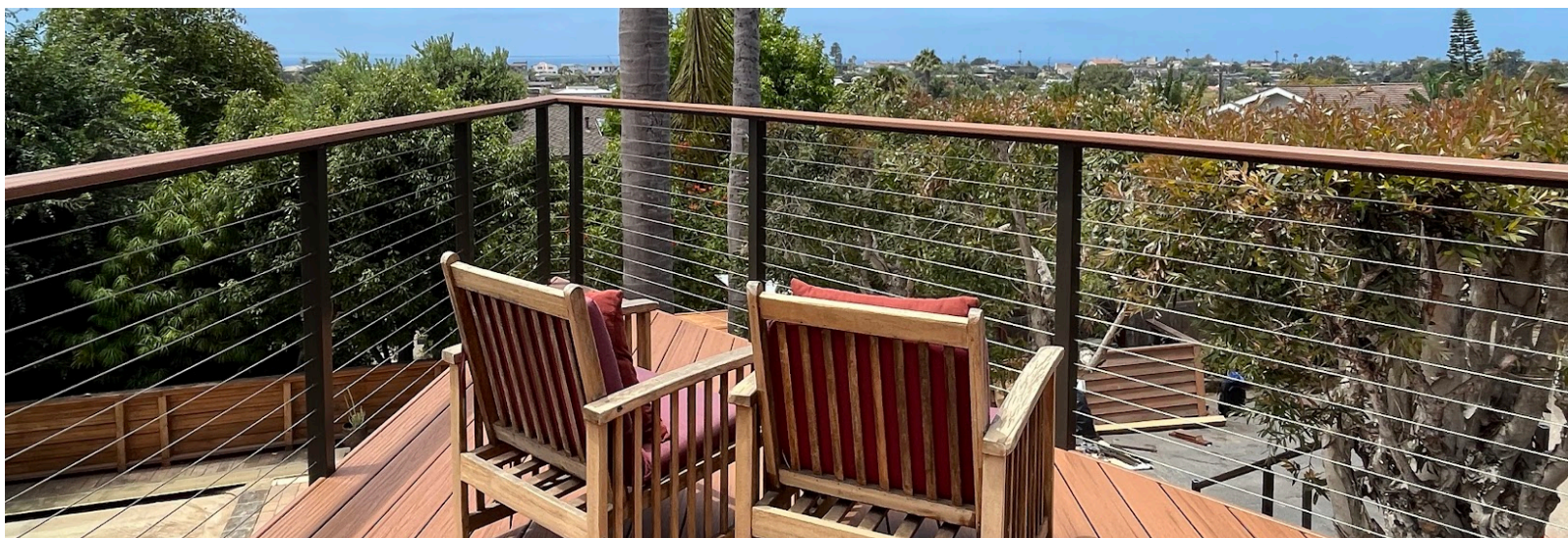

Push-Lock® Lag



Exposed, swageless, non-tensioning, face-of-the-post-mounted fitting suitable for use on level runs only, and is available for 1/8" and 3/16" diameter 1x19 stainless steel cable.

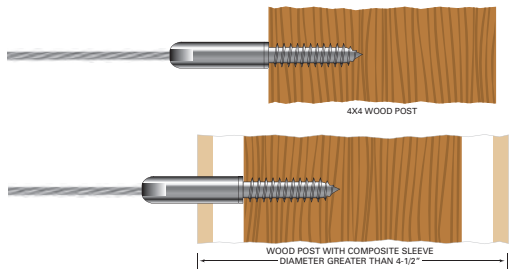

CABLE DIA.	PART NO.
1/8"	PL-LAG-4
3/16"	PL-LAG-6

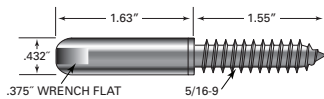

- Must be used with a tensioning fitting on the opposite end of the run.
- Fitting is installed into a pre-drilled hole in the wood end post by rotating the fitting (with a wrench placed onto wrench flats machined into the fitting) to drive the lag thread into the hole until the fitting shoulder is flush with the post face. Because the wrench flat is at the back of the fitting, it can be used with sleeved posts as well.
- Cable attaches to the fitting via our Push-Lock® locking wedge system which requires no special tools.

Push-Lock® with Lag Clevis

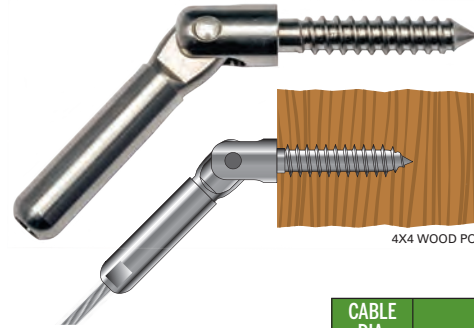

4X4 WOOD POST

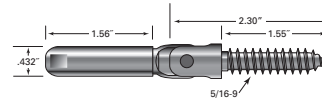

CABLE DIA.	PART NO.
1/8"	PL-LAG-CL-TE4-1
3/16"	PL-LAG-CL-TE6-1

Exposed, swageless, non-tensioning, face-of-the-post-mounted fitting suitable for level or pitched runs, and is available for 1/8" and 3/16" diameter 1x19 stainless steel cable.

- Can be used with any tensioning fitting on the opposite end of the run.
- Fitting is installed into a pre-drilled hole in the wood end post. Drive the lag thread into the hole until the fitting shoulder is flushed with the post face.
- Cable attaches to the body via our Push-Lock® locking wedge system which requires no special tools.

Additionally available in extended length lag versions.*

- While this fitting can be used on pitched or level runs, it is most appropriate for pitched runs because the body of the fitting pivots at the clevis.

Push-Lock® Toggle

Exposed, swageless, non-tensioning, face-of-the-post-mounted fitting suitable for use on level runs and is only available for 1/8" diameter 1x19 stainless steel cable.

- Can be used with any fitting on the opposite end of the run.
- Toggle is installed into a pre-drilled hole in the end post. No tapping required!
- Cable attaches to the fitting via our Push-Lock® locking wedge system which requires no special tools.
- This is a non-tensioning fitting. Fitting on the opposite end of the cable run must be a tensioning fitting.

Order #: PL-CNT-4

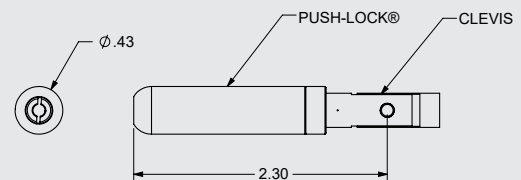

CABLE DIA.	PART NO.
1/8"	PL-CNT-4

Pull-Lock®



Concealed, swageless, non-tensioning, through-the-post-mounted fitting suitable for use on level or pitched runs, and is available for 1/8", 3/16", and 1/4" diameter 1x19 stainless steel cable.

- Must be used with a tensioning fitting on the opposite end of the run.
- Fitting is installed into a pre-drilled hole in the end post.
- Using the Pull-Lock® fitting on level or pitched runs requires enough clearance on the back side of the end post to install the fitting through the back side of the post. That amount of clearance depends on the length of Pull-Lock® chosen.
- Fitting is furnished with a Delrin® or flat washer to install between the shoulder of the fitting and the end post to protect the surface of the finish tension is applied
- Cable attaches to the fitting via our Push-Lock® locking wedge system which requires no special tools.

This fitting is similar to the Push-Lock®, except the cable passes through the Pull-Lock®, meaning you can cut the excess cable where it exits the fitting – no need to measure the cable before cutting. This feature eliminates the need for taking accurate cable length measurements (as is required when using a Push-Lock® fitting).

The Pull-Lock® can be used on a pitched run in a hole drilled horizontally through the end post. The cable will exit the fitting at an angle. To properly use this fitting on a pitch, it's recommended you choose a Pull-Lock® that is the same length as the cross section of your end post.

This fitting can be used on a pitched application, using the same horizontally drilled method for 4x4 wood posts, by installing a post protector tube into the face of the post where the cable exits at an angle (the post protector tube protects the face of the post from abrasion and furrowing as the cable is tensioned). Post protector tube is **sold separately** (see page 4).

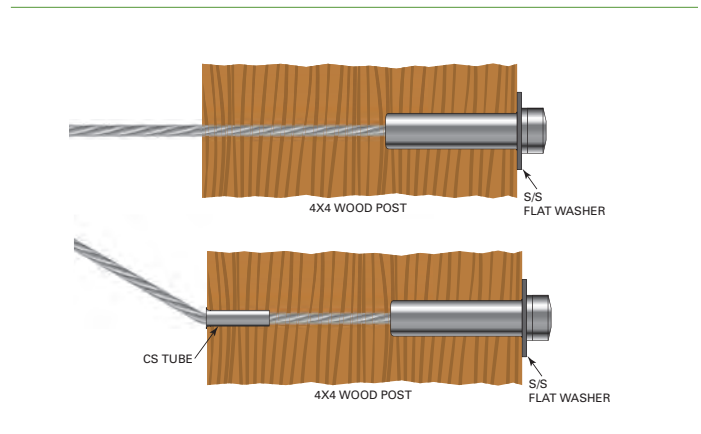
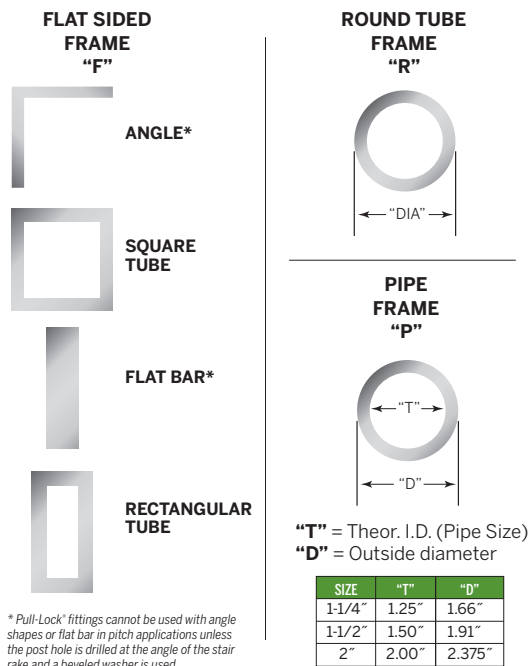

FRAMING OPTIONS FOR PULL-LOCK® FITTINGS

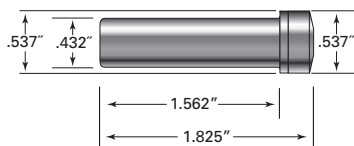

1/8" CABLE PART NO.	3/16" CABLE PART NO.	1/4" CABLE PART NO.	FRAME "F"	FRAME "R"	FRAME "P"	"L" LENGTH
PUL-4-12	PUL-6-12	N/A	1-1/2"	1-1/2"	1-1/4"	1.562"
PUL-4-1.810	PUL-6-1.810	PUL-8-22	N/A	N/A	1-1/2"	1.810"
PUL-4-2.030	PUL-6-2.030	PUL-8-32	2"	2"	N/A	2.030"
PUL-4-2.300	PUL-6-2.300	N/A	N/A	N/A	2"	2.300"
PUL-4-2.375	PUL-6-2.375	N/A	2-3/8"	2-3/8"	N/A	2.375"
PUL-4-2.530	PUL-6-2.530	PUL-8-2.530	2-1/2"	2-1/2"	2-1/2"	2.530"
PUL-4-3.030	PUL-6-3.030	PUL-8-3.030	3-1/2"	3-1/2"	3"	3.030"

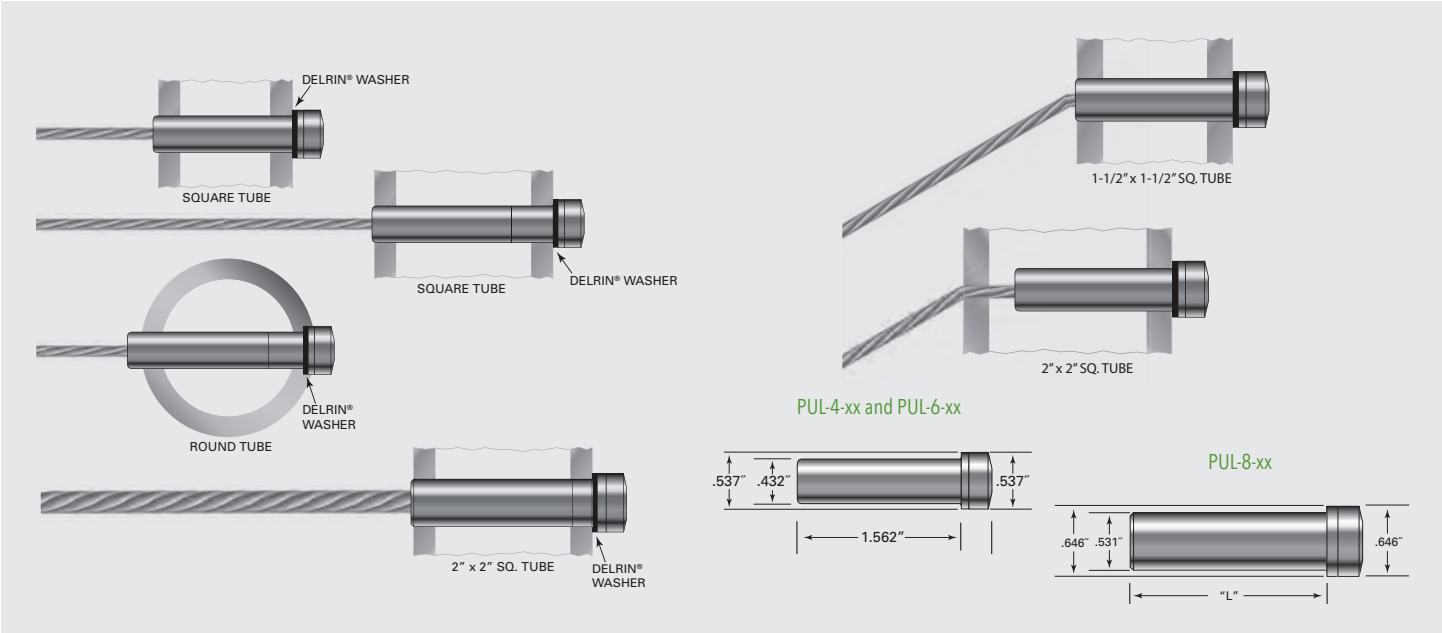

SWAGED TENSIONING FITTING

Adjust-A-Body® with Concrete Anchor Bolt



Exposed, swaged, tensioning, face-of-the-surface-mounted fitting recommended for level runs terminating at a concrete surface only. Fitting is available for 1/8", 3/16", and 1/4" diameter 1x19 stainless steel cable.

- Can be used with any fitting on the opposite end of the run.
- A concrete anchor is driven into a pre-drilled hole in the concrete surface. Short thread of the Anchor Bolt portion of the fitting is threaded into the concrete anchor.
- Cable is retained within the body portion of the fitting by a ferrule swaged onto the end of the cable. (see page 7)
- Lock Nut is installed all the way onto the exposed machine thread of the Anchor Bolt, followed by the body, which is secured onto the anchor bolt, creating tension on the cable.
- Once sufficient tension is achieved Lock Nut is secured against the end of the body to prevent the fitting from loosening.

Use of this fitting requires an appropriately sized ferrule swaged onto the cable. Ferrule sold separately, see information on page 9. We recommend the Red Head® Concrete Anchor, available for purchase at many building supply retailers and distributors throughout the U.S.

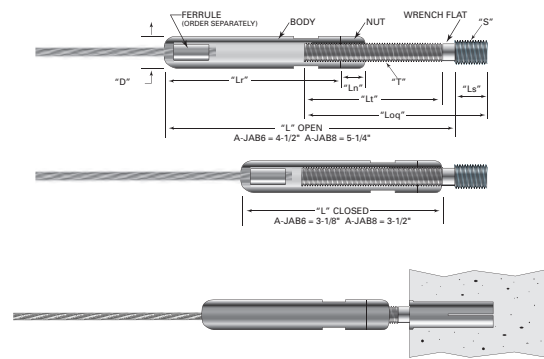

TYPE 316 STAINLESS STEEL

CABLE DIA.	PART NO.	USE WITH FERRULE NO.	"S"	"T" THREAD	"LS"	"LT"	"LOQ"	"LN"	"LR"	"D"	USE WITH "RED HEAD" BRAND	
											CARBON STEEL	STAINLESS
1/8"	A-JAB6	F-4	3/8-16	5/16-24 LH	.500"	2.313"	3.188"	.375"	2.75"	.490"	RM-38	SRM-38
3/16"	A-JAB6	F-6										
1/4"	A-JAB8	F-8	1/2-13	7/16-20 LH	1.125"	2.500"	3.938"	.500"	3.00"	.617"	RM-12	SRM-12

Red Head® is a trademark owned by Illinois Tool Works Inc. Illinois Tool Works is not affiliated with ASD



SWAGELESS NON-TENSIONING FITTING

Push-Lock® Concrete Anchor Bolt



Exposed, swageless, non-tensioning, face-of-the-surface-mounted fitting suitable for use on level runs only, and is available for 1/8" and 3/16" diameter 1x19 stainless steel cable.

- Must be used with a tensioning fitting on the opposite end of the run.
- Concrete anchor is driven into a pre-drilled hole in the concrete surface.

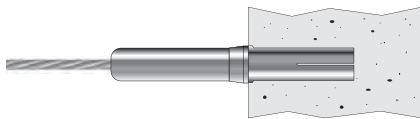

- Anchor Bolt portion of the fitting is threaded into the Concrete Anchor.
- Cable attaches to the fitting via our Push-Lock® locking wedge system which requires no special tools.
- We recommend the Red Head® Concrete Anchor, available for purchase at many building supply retailers and distributors throughout the U.S..

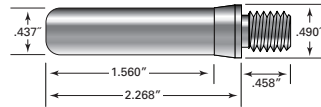

CABLE DIA.	PART NO.
1/8"	PL-AB4
3/16"	PL-AB6



EQUIPMENT, ACCESSORIES, RAILING COMPONENTS

Swager Rentals

Find yourself needing to cut and swage cables in the field? We have swager kits available for rent that come complete with the swager head, hydraulic pump, cable cutters, cable gripping pliers, and other tools to help ensure you have the everything you need to successfully complete your cable installation.

The 650 Kit comes with an electric pump; the 610 comes with a pump that requires a compressor. For the 610, you need to supply an air compressor to power the pump and the swager. Requirements are minimum 5.8 CFM at 90 PSI and a minimum 20 gallon tank. Air pressure should be regulated to a minimum of 120 PSI, not to exceed 140 PSI. Each of the components in the rental kits is also available for sale separately.



650 Swager Rental Kit for 1/8", 3/16", 1/4", 5/16", and 3/8" cable



610 Swager Rental Kit for 1/8" and 3/16" cable only

Model 650 Swager

For swaging 1/8" through 3/8" diameter cable fittings. Use with Air Over or Electric Hydraulic Pump.

Order 650 SWAGER



Electric Hydraulic 120V Pump

Increases swaging speed versus the Air Over Hydraulic Pump. No compressor needed.

Order HYD PUMP -ELECTRIC



650 Shipping Container/ Tool Box

With compartments for cable cutting and installation tools and either air over or electric pump. Mounted to 4x4 risers for safer, easier loading/off-loading.

Order 650 TOOL BOX



Model 610 Swager

Hand held. For swaging 1/8" and 3/16" diameter cable fittings. Use with Air Over or Electric Hydraulic Pump.

Order 610 SWAGER



Air Over Hydraulic Pump

Air driven. Powers Model 610 or 650 Swager. Requires an air compressor capable of delivering at least 5.8 CFM at 90 PSI and a minimum 20-gallon tank. Minimum 1/4" I.D. air hose with a 1/4" male pipe thread required (not included).

Order HYD PUMP-AIR



610 Shipping Container/ Tool Box

With compartments for cable cutting and installation tools and air over pump. Order 610 TOOL BOX



Cable Cutter

For burr-free cutting of cable. For light-duty use to cut 1/8" cable, Order C-7

To cut cable 1/4" diameter and under , Order C-9 (pictured).

To cut cable up to 3/8" diameter . Order C-12



Cable Gripping Pliers

Locking pliers with machined jaws to grip the cable as you are tensioning the cable. This keeps the cable from turning and prevents damage to the cable when cable is being tensioned.

Order PLIERS



Cable Release

Releases cable from Push-Lock ® and Pull-Lock® type fittings before cables are tensioned. For 1/8" cable only.

Order PL-KEY



PL Lag Driver

Use the driver when installing a Push-Lock ® with a lag. This helps align the socket with the wrench flat for an easier installation.

Order PL LAG DRIVER



Radius Ferrule Gauge

Use this gauge to confirm that the radius Ferrule has been properly swaged. The fitting is properly swaged if it fits into the appropriate slot.

Order RF-GAUGE



Grommet Installation Tool Set

Needed to properly install grommets. Place grommet on tool, align grommet over hole, and tap lightly with a hammer (hammer not provided with rental tools).

Order GROMMET TOOL SET



Cable Tension Gauge

Check the tension on your cables with these easy-to-use gauges. For cable diameter of 1/8", 3/16" and 1/4".

Order PT-CR

For cable diameter of 1/4" through 3/8",
Order PT-3



Industrial Pre-Tensioner

Industrial Pre-Tensioner is recommended to be used when installing longer runs of cable and threading through multiple posts. This tool allows you to pretension the cable at an intermediate post location. Use the gauge to measure the cable tension. For use with 1/8" and 3/16" cable only.

Order PRETENSIONER01



Pre-Tensioner

A Pre-Tensioner can be used when installing longer runs of cable. It allows you to tension the cable through the last intermediate post, making it easy to connect to the last (end) post. When renting installation tools, Pre-Tensioners must be requested.

Order PT-250



Pre-Tensioner Locking Pliers

Special Pre-Tensioner Locking Pliers are used with the Pre-Tensioner. Each cable diameter requires individual pliers which must be ordered separately. For 1/4" cable, Order VGJ-PT8C
For 5/16" cable, Order VGJ-PT10C
For 3/8" cable, Order VGJ-PT12C

Drill Guide

Drill straight holes through your wood posts with a steel drill guide. Use the drill guide to drill your pilot holes. Subsequent drilling will follow pilot holes. Clamp the guide to post and drill. It is best to drill one side, then the other. When ordering, allow space for clamps. A 6"-long drill bit is included that can also be used to drill your cable through-holes. Contact factory for DRILL GUIDE ORDER FORM.



Stainless Steel Spacers

Used to support thin-walled double end post design or allow for Receiver extension in a stair system.



TYPE 316 STAINLESS STEEL

CABLE DIA.	PART NO.	LENGTH	OUTSIDE DIA.	WALL THICKNESS
1/8", 3/16"	SPC-R6-.500	.500"	5/8"	.083"
1/8", 3/16"	SPC-R6	.970"	5/8"	.083"
1/4"	SPC-R8	.970"	3/4"	.095"

Cable

Four sizes of cable are offered for use with the Railing Fitting and Hardware: 1/8", 3/16", 1/4", and 3/8".

1 x 19
Non-Flexible

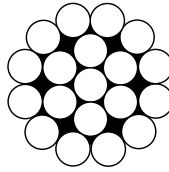

**MINIMUM BREAKING STRENGTH (IN LBS.)
FOR 1X19 STRAND TYPE 316 STAINLESS STEEL CABLE**

CABLE DIAMETER	1/8"	3/16"	1/4"	3/8"
BREAKING STRENGTH	1,780	4,000	6,900	14,800

PART	PRODUCT DESCRIPTION	PART NO.
1/8" SS Cable	1' increments	CH-CABLE-1/8
	500' spool	CH-CABLE-.125X500
	5,000' spool	CH-CABLE-.125X5000
3/16" SS Cable	1' increments	CH-CABLE - 3/16
	5,000' spool	CH-CABLE-.187X5000
1/4" SS Cable	1' increments	CH-CABLE- 1/4
	2,500' spool	CH-CABLE.250X5000
3/8" SS Cable	1' increments	CH-CABLE- 3/8
	2,500' spool	CH-CABLE.375x2500

We recommend 1x19 construction, Type 316 stainless steel cable for cable railing applications. 1x19 strand cable is engineered to hold static loads without stretching, and is relatively stiff.

Beveled Washers
(for flat-sided frames only)

Made of stainless steel for use with Invisiware® Receivers, Push-Lock® tensioners and Pull-Lock® fittings on stairways or slopes where you need to drill your end post holes at an angle.



Isolation Bushing with Stainless Steel Washer
When placed over the fitting before inserting into the post, this bushing is used to prevent bimetallic corrosion. Must be used with 7/16EXP-SS washer to secure fittings in post.
Order B-687-562-437 and 7/16EXP-SS

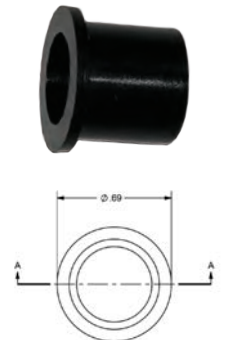

TYPE 316 STAINLESS STEEL FOR -6 AND -8 BWS

CABLE DIA.	STAIR/SLOPE PITCH	PART NO.
1/8", 3/16"	30° - 33°	BW32-6
		XBW32-6-B2
	34° - 36°	BW35-6
		XBW35-6-B2
37° - 39°	BW38-6	
1/4"	30° - 33°	BW32-8
	34° - 36°	BW35-8
	37° - 39°	BW38-8
5/16", 3/8"	30° - 33°	BW32-12
	34° - 36°	BW35-12
	37° - 39°	BW38-12

Cut-off Tool

Use to cut cable flush with the end of pull-Lock® fittings, and to cut excess threads off stud-type tensioners. Includes mandrel and two cut-off wheels.
Order CUT-OFF KIT



Stainless Steel Cleaner and Protectant

Dissolves minor corrosion and leaves a protective coating that lasts for months. Includes an 8-oz. spray-on rust and stain remover and a 4-oz. bottle of protectant.
Order E-Z CLEAN



Anodized Aluminum Cable Brace

3/4" x 3/4" tube, 42" long for cutting down to any size rail height. Holes pre-drilled at 3-1/8" on center, 13 holes total. For use between structural posts to keep cables code compliant on level runs. Use cable brace plugs to attach to top and bottom rail or deck.



Order CB-42-AN-AL-13

Black Aluminum Cable Brace

Order CB-42-BL-AL-13

Anodized Aluminum Cable Brace for Stairs

3/4" x 3/4" tube, 42" long for cutting down to any size rail height. Comes undrilled so slots can be field-drilled to match cable array.



Order CB-42-AN-AL

Black Aluminum Cable Brace for Stairs

Order CB-42-BL-AL

Stainless Steel Cable Brace

1/4" x 1" in 2 lengths, for 36" and 42" high rails. Holes pre-drilled at 3-1/8" on center, 10 holes in short length, 12 holes in long. For use between structural posts to keep cables code compliant on level runs. Weld to metal frames; use cable brace floor plates for attaching to wood. Type 316 Stainless Steel



Order CB-34.5-SS-10 or CB-40.5-SS-12

Stainless Steel Cable Brace for Stairs

1/4" x 1" in 2 lengths, for 36" and 42" high rails. Slots pre-drilled at 3-1/8" on center, 10 slots in short length, 12 holes in long. For use between structural posts to keep cables code-compliant on stair runs. Weld to metal frames; use cable brace floor plates for attaching to wood. Must be field-chamfered to match stair angle. Type 316 Stainless Steel

Order CBS-34.5-SS-10 or CBS-40.5-SS-12

Stainless Steel Cable Brace Floor Plates

For mounting cable braces to top or bottom rail or deck. Compatible with stairs.

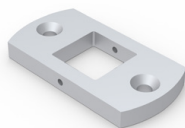

2-1/4" x 1-1/4" x 1/4"

Type 316 Stainless Steel

Order FLP-CBS

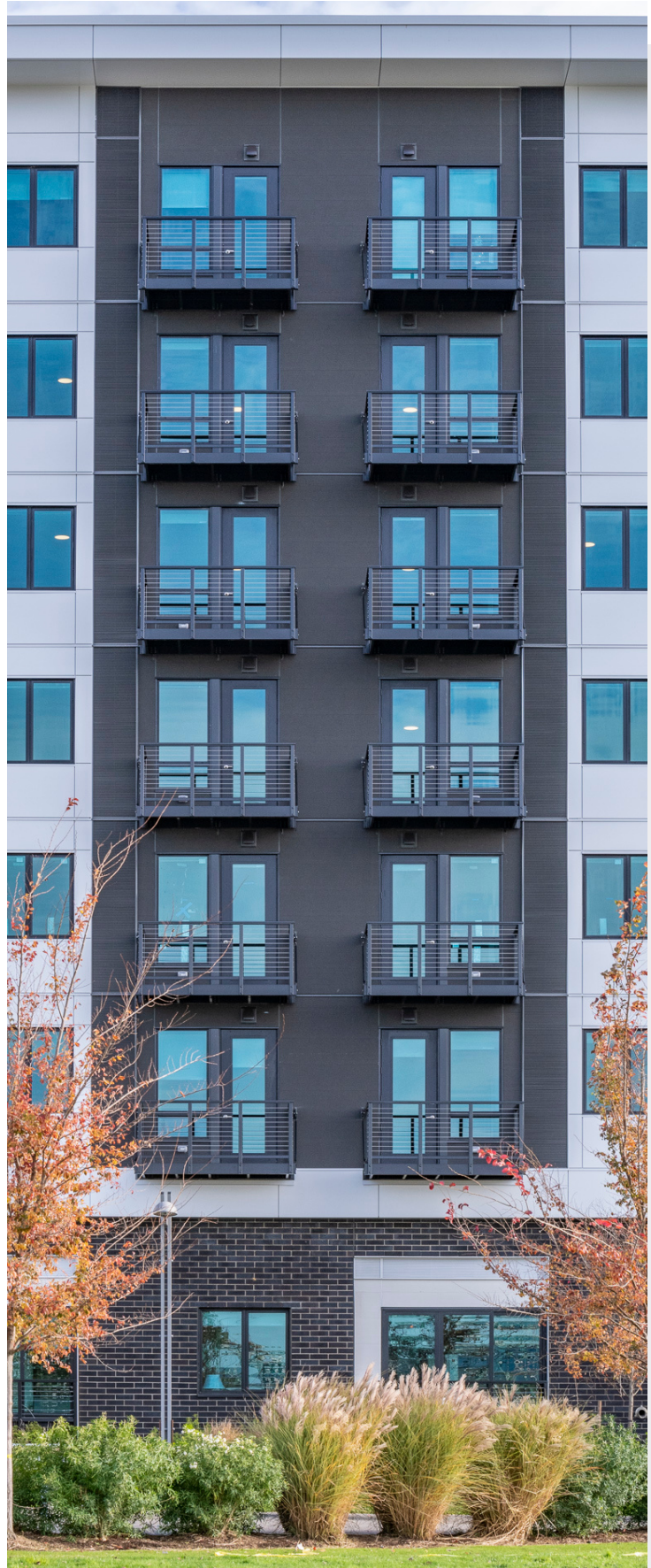

Cable Grommets

Cable grommets are offered for popular cable diameters of 1/8", 3/16" and 1/4". They help prevent rust in exterior applications or where moisture is a factor, by providing a barrier between the cable and the painted or powder-coated surface through which the cable is drawn when being installed. They help prevent noise in interior applications by dampening vibration in the cables. Cable grommets are installed (after the paint or powder coating is applied) into holes in intermediate posts, cable braces and, in the case of the Invisiware® Radius Ferrule, Push-Lock®, and Pull-Lock® fittings into the end post holes through which the cable exits.

They are offered in black UV resistant Delrin®.

Order cable grommets by diameter of cable and post through which the cable will be drawn.

GI grommets available for stair post slotted holes.



CABLE DIA.	INTERMEDIATE POST MATERIAL (NOT SLOTTED FOR STAIRWAY)				INTERMEDIATE POST MATERIAL SLOTTED FOR STAIRWAY PITCH UP TO 37°		
	SCHEDULE 40 1-1/4" 1-1/2" 2" PIPE	SQ. OR RECT. TUBE WITH .120" WALL	1/4" CABLE BRACE OR SQ. OR RECT. TUBE WITH .250" WALL	1/2" FLAT BAR	SCHEDULE 40 1-1/4" 1-1/2" 2" PIPE	SQ. OR RECT TUBE WITH .120" WALL	1/4" CABLE BRACE OR SQ. OR RECT. TUBE WITH .250" WALL
1/8", 3/16"	G-C6-1	G-C6-2	G-C6-4	G-C6-.500	GI-C6-1	GI-C6-2	GI-C6-4
1/4"	G-C8-1	G-C8-2	G-C8-4	NA	GI-C8-1	GI-C8-2	GI-C8-4

Cable grommets are available in lots of 100 each.

- GI grommets available for stair post slotted holes.

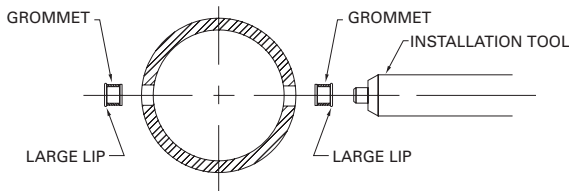

CABLE DIA.	END POST MATERIAL USING RADIUS FERRULE, PUSH-LOCK® OR PULL-LOCK® FITTINGS	
	SCHEDULE 80 1-1/4"*, 1-1/2" OR 2" PIPE	SQ. OR RECT. TUBE WITH .250" WALL*
1/8" & 3/16"	G-C6-3	G-C6-4
1/4"	G-C8-3	G-C8-4

*Cable grommets not required for Push- or Pull-Lock® applications where fitting extends through both walls of post frame.



CABLE RAILING REFERENCE GUIDE

1 Cut-To-Length Cables With One Factory-Swaged Fitting, One Swageless Fitting

Provide us approximate field measurements for each cable run. We factory swage the tensioner to one end. A swageless non-tensioning fitting is included for you to install on the other end. The cable is delivered 3" longer than needed for each run to be trimmed to exact length onsite. For Pull-Lock® swageless fittings, use a cut-off wheel to cut the cable as closely as possible to where it exits the fitting.

- You do not have to supply exact field measurements from post to post.
- The holes drilled through the intermediate posts can be just slightly larger than the cable diameter for a tight fit around the cable.
- It helps reduce cable deflection



3 Cable On A Spool, Swage-On Fittings, Swager Rental Kit

Spooled bulk cable, a swager rental kit and swage-on fittings are provided. You will do all the cutting and swaging of cables on the job.

- We provide you with the components and the means to put them together.
- You can use our economical swage-on fittings on both ends of the cable.
- Drill the holes through the intermediate posts slightly larger than the cable diameter for a tight fit around the cable.
- It helps to reduce cable deflection

2 Cut-To-Length Cables With Both Ends Factory-Swaged

Provide exact field measurements for each cable run. We cut and swage both ends of the cable to final installation length and ship them to you for your project.

- The swage-on fittings are more economical and you don't have to swage the cable in the field
- Drill intermediate holes slightly larger than the smallest fitting swaged to the cable.
- Saves on time and labor.



4 Cut-To-Length Cables With One Factory-Swaged Fitting, One Fitting To Be Swaged In The Field

Provide exact field measurements for each cable run. We cut the cable to final installation length and factory swage one end to the cable. We ship the pre-cut cable and the fitting for the other end, you swage it on in the field (either with one of our rental swagers or yours, if you own one). No further trimming necessary.

Or, you provide a longer measurement than necessary. We cut the cable longer than needed for each run and factory swage one end to the cable. We ship you the pre-cut cable and the fitting for the other end, you trim to final length and swage the other fitting in the field

- Drill the holes through your intermediate posts slightly larger than the cable diameter for a tight fit around the cable.
- It helps to reduce cable deflection



The Columbia



U.S.A.
Manufacturer



WA - 1801 132nd Ave. E STE 100 Sumner, WA 98390 | P: 253-833-4343

OR -13444 NE Jarrett St. Portland, OR 97230 | P: 971-645-4201

www.americanstructures.com

Engineering data, downloadable specifications and drawings are available for cable railing products.