

BORING INSTRUCTIONS

INVISIWARE® WELDED RECEIVER

Used with double end post construction using 2"x1' or 3"x1' rectangular tubing with 1-inch spacers.

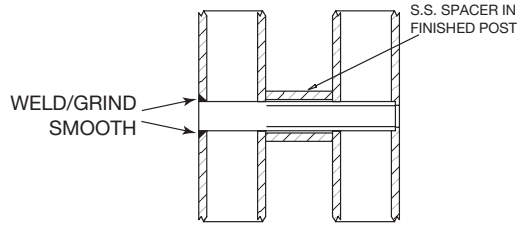
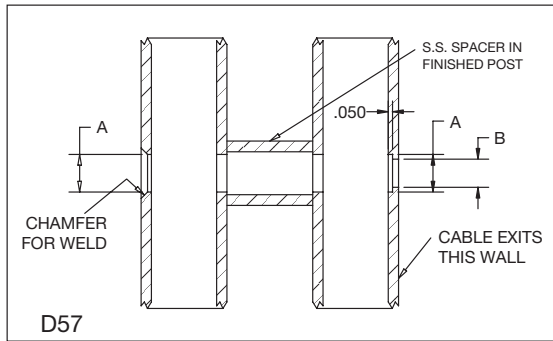

Part No.	Used with Cable Dia.	Hole Diameters	
		A	B
WR-6-5A	1/8"	7/16" (.437")	21/64" (.328")
WR-6-5B	3/16"		
WR-8-5A	1/4"	17/32" (.531")	29/64" (.453")
WR-8-5B			

Note: When properly installed, the Welded Receiver will rest against the lip of the inside wall through which the cable exits.

Used with square or rectangular tubing with minimum .250" wall thickness, or round steel tubing with wall thickness at least comparable to SC80 pipe.

If using round steel tubing, wall thickness must be at least comparable to SC80 pipe.

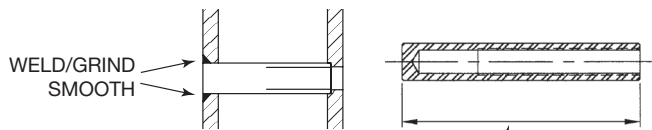
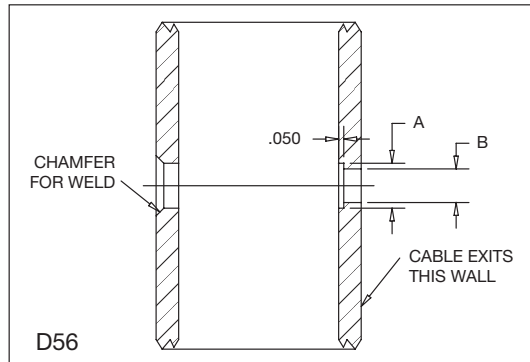

Part No.	Used with Cable Dia.	Hole Diameters	
		A	B
WR-6-5A	1/8"	7/16" (.437")	21/64" (.328")
WR-6-5B	3/16"		
WR-8-5A	1/4"	17/32" (.531")	29/64" (.453")
WR-8-5B			

Note: Cut Welded Receiver to length. Allow for dimension for part to rest against the lip on the inside wall through which the cable exits.

Used with minimum SC80 round pipe.

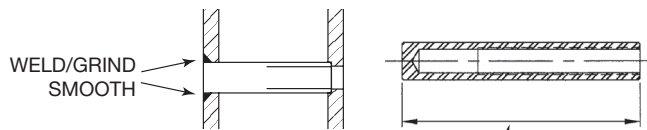
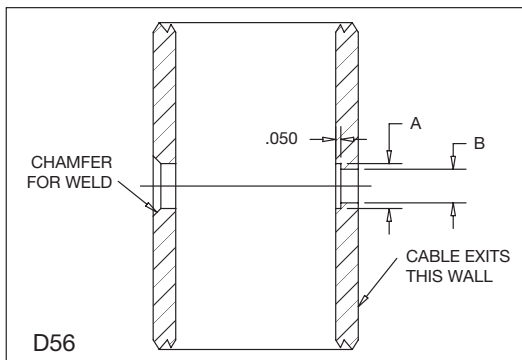

Part No.	Used with Cable Dia.	Hole Diameters	
		A	B
WR-6-5A	1/8"	7/16" (.437")	21/64" (.328")
WR-6-5B	3/16"		
WR-8-5A	1/4"	17/32" (.531")	29/64" (.453")
WR-8-5B			

Cut Welded Receiver to length as follows:
 1-1/4" std. Sc 80 Pipe: 1.44"
 1-1/2" std. Sc 80 Pipe: 1.675"
 2" std. Sc 80 Pipe: 2.137"