

VERTICAL RAILING BORING DIAGRAMS

Top Rail Holes

Top rail holes on the underside (only) of the top rail are drilled and tapped on 3.25" centers to accept Invisiware® 5/16-24 Threaded Studs for 1/8" or 3/16" diameter cable. (Note that every eighth cable is replaced with a rail brace, to keep the top and bottom rails from bending).

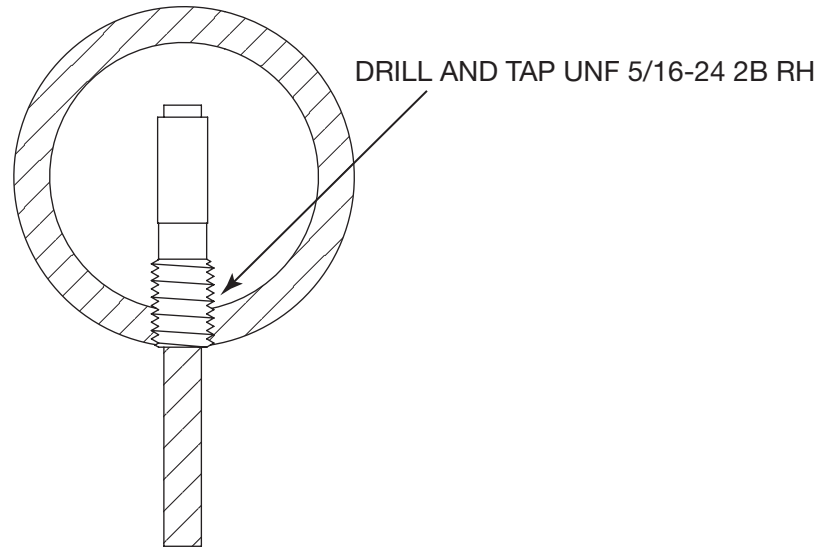

Bottom Rail Holes

Bottom rail holes are drilled 3.25" centers to accept Invisiware® Receivers for 1/8" or 3/16" diameter cable. (Note that every eighth cable is replaced with a rail brace, to keep the top and bottom rails from bending).

