

SWAGING FERRULE

The Swaging Ferrule is used to retain an Adjust-A-Jaw®, Adjust-A-Body® or a Fixed Jaw onto a piece of cable.

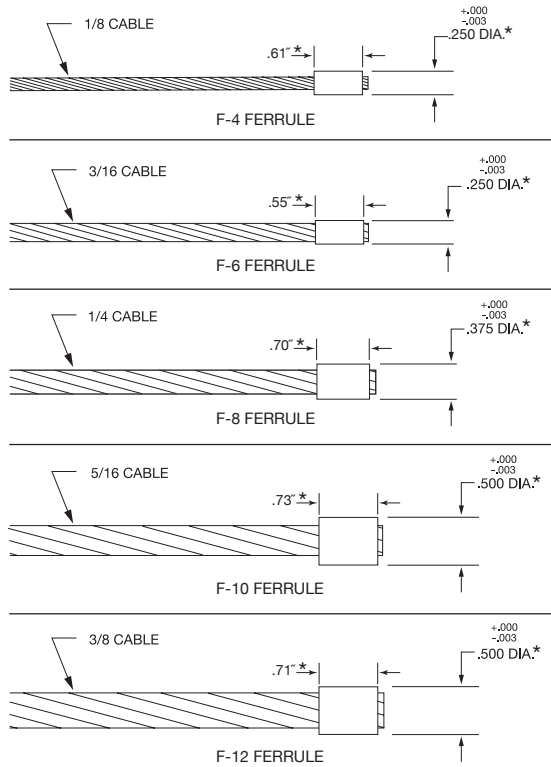

**After swaging*



MATERIAL: TYPE 316 STAINLESS STEEL

SWAGING STUD

The Swaging Stud is used in conjunction with an Invisiware® receiver or Welded Receiver. This fitting provides a means of tensioning a cable in as small an area as is feasible. The threaded surface of the stud is treated with a moly-based surface treatment that is baked on. This will prevent thread galling and sticking under extreme loads and environments.

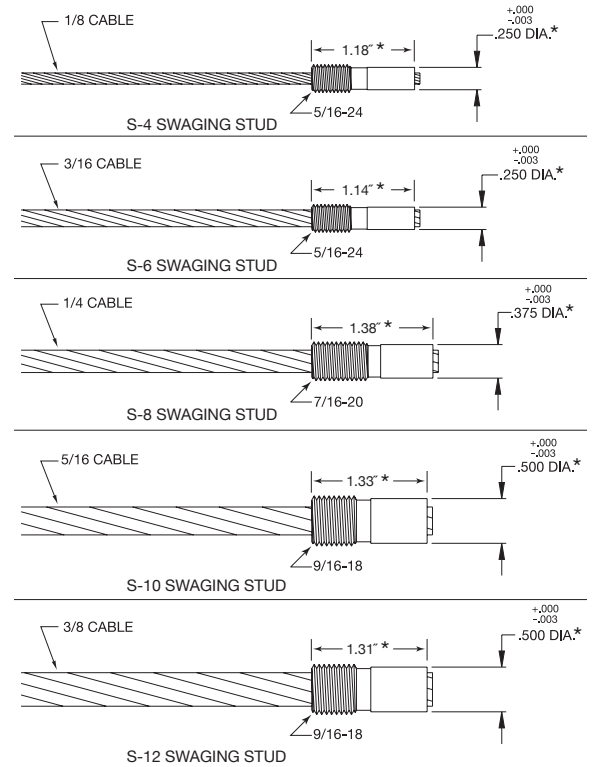

**After swaging*



MATERIAL: TYPE 316 STAINLESS STEEL