

# BORING INSTRUCTIONS

## INVISIWARE® FIXED TAB

Used with double end post construction using 2"x1" or 3"x1" rectangular tubing with 1-inch spacers.

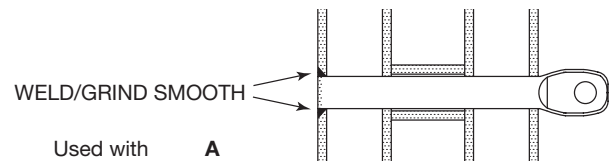
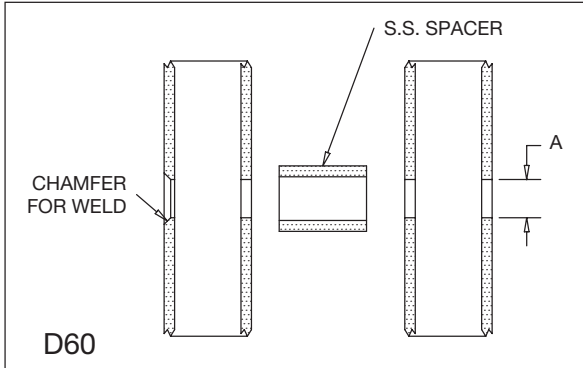

Part No.	Used with Cable Dia.	A Hole Dia.
F-T6-5A	1/8"	3/8" (.375")
F-T6-5B	3/16"	
F-T8-5A	1/4"	9/16" (.562")
F-T8-5B		

Used with square or rectangular tubing with minimum .250" wall thickness, or round steel tubing with wall thickness at least comparable to SC80 pipe.

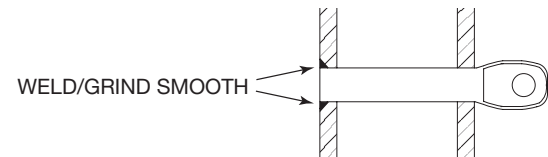
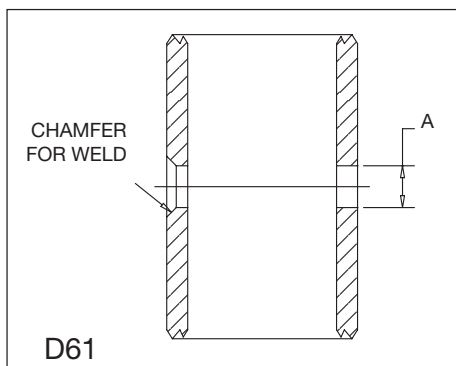

Part No.	Used with Cable Dia.	A Hole Dia.
F-T6-5A	1/8"	3/8" (.375")
F-T6-5B	3/16"	
F-T8-5A	1/4"	9/16" (.562")
F-T8-5B		



Cut Fixed Tab round shank to length.  
Allow for chamfer.

Used with minimum SC80 pipe.

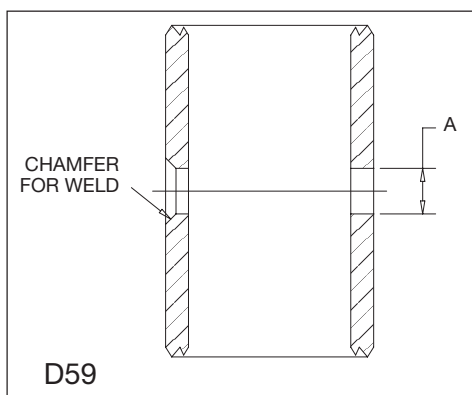

Part No.	Used with Cable Dia.	A Hole Dia.
F-T6-5A	1/8"	3/8" (.375")
F-T6-5B	3/16"	
F-T8-5A	1/4"	9/16" (.562")
F-T8-5B		

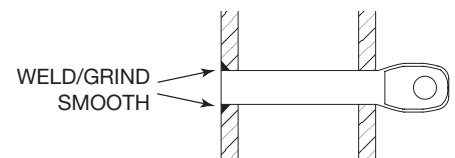

Cut Fixed Tab round shank to length as follows:  
1-1/4" std. Sc 80 Pipe: 1.60"  
1-1/2" std. Sc 80 Pipe: 1.84"  
2" std. Sc 80 Pipe: 2.31"

