

- A. MEASURE FROM THE FINISHED FLOOR THE HEIGHT OF THE DOOR PLUS $\frac{1}{2}$ ".
- B. MARK THE LINE LOCATION AND USING A LEVEL DRAW A HORIZONTAL LINE ACROSS THE OPENING.
- C. NEXT MARK A VERTICAL LINE IN THE CENTER OF THE DOOR OPENING.

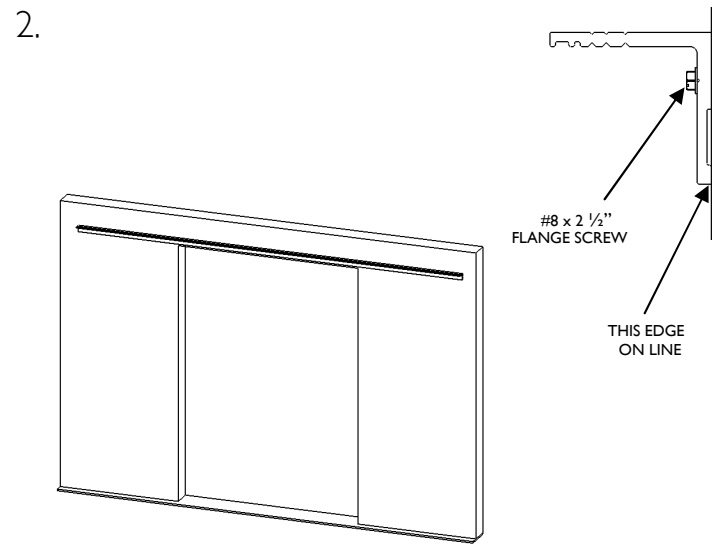

- A. PLACE THE L-BRACKET IN POSITION (ABOVE THE HORIZONTAL LINE AND CENTERED ON THE VERTICAL LINE).
- B. ATTACH THE L-BRACKET TO THE WALL USING #8 X $2 \frac{1}{2}$ " FLANGE SCREWS.

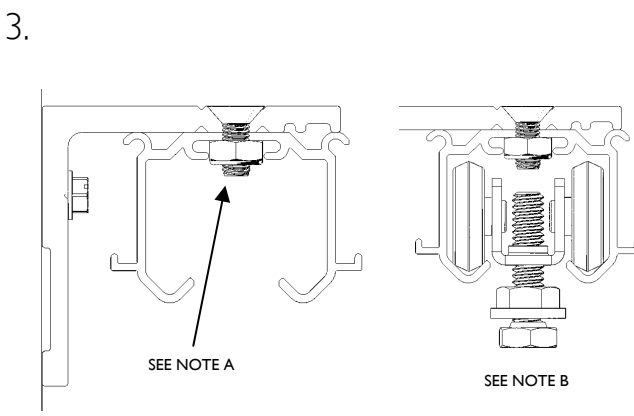

- A. ATTACH THE TRACK TO L-BRACKET USING #10-32 X $\frac{1}{2}$ " FHSC SCREWS AND #10-32 LOCK NUTS.
- B. INSERT THE TOP ROLLERS INTO TRACK (PRE-ADJUST BOTH TO THE MID-RANGE).

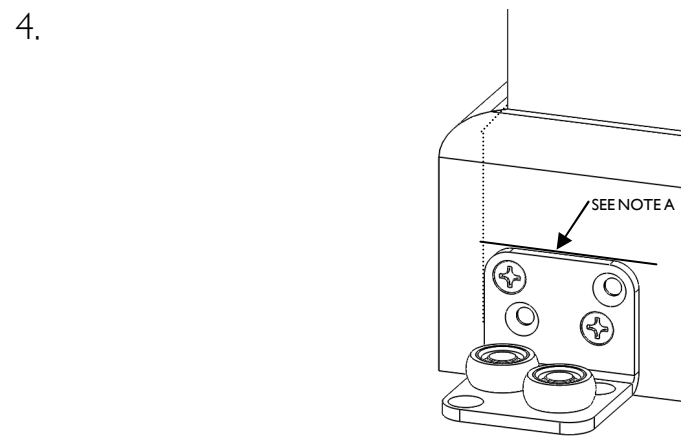

- A. FROM THE HORIZONTAL LINE IN INSTRUCTION #1, MEASURE DOWN THE WALL THE HEIGHT OF THE DOOR MINUS $\frac{3}{4}$ " AND MARK A LINE TO ESTABLISH THE VERTICAL LOCATION OF THE BOTTOM ROLLING SYSTEM.
- B. POSITION THE ASSEMBLY ON THE WALL OR BASEBOARD ALONG THE LINE AS SHOWN.
- C. ALIGN THE EDGE OF THE ANGLE BRACKET WITH THE EDGE OF THE WALL AS SHOWN AND ATTACH THE ASSEMBLY USING TWO #8 X $\frac{3}{4}$ " FH SCREWS.

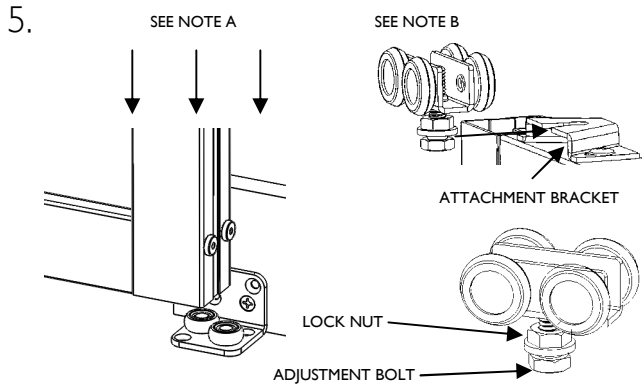

- A. POSITION THE DOORS OVER THE LOWER ROLLERS AS SHOWN.
- B. INSERT THE TOP ROLLERS WITH THE ATTACHMENT BRACKETS AS SHOWN.
- C. ADJUST THE DOORS, USING THE ADJUSTMENT BOLTS ON THE TOP ROLLERS; SO THE DOORS REMAIN INSERTED WITH THE BOTTOM ROLLING SYSTEM AND OPERATE SMOOTHLY AS THE DOORS ARE OPENED AND CLOSED.
- D. TIGHTEN THE LOCK NUTS TO SECURE THE ADJUSTMENT BOLTS.

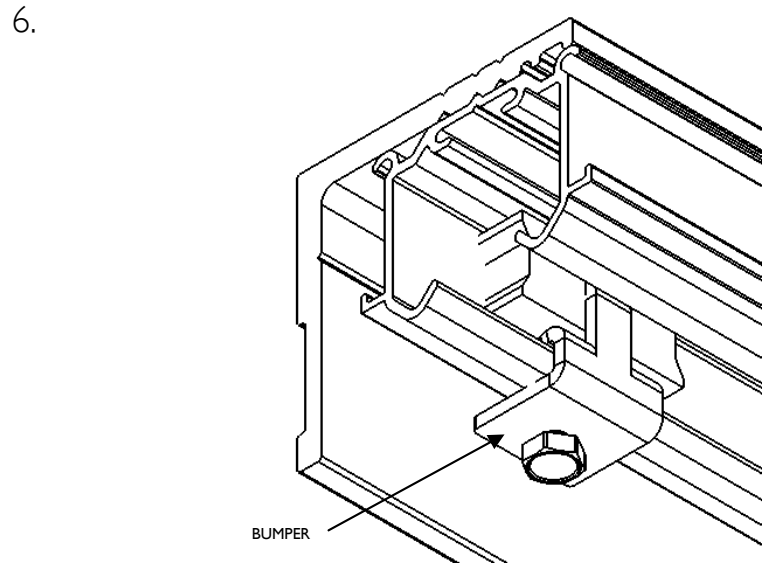

- A. INSERT AND TIGHTEN BUMPERS SO THE DOORS COME INTO CONTACT WITH THE BUMPERS, APPROXIMATELY 1/4" BEFORE STRIKING THE BOTTOM ROLLING SYSTEM IN BOTH DIRECTIONS.

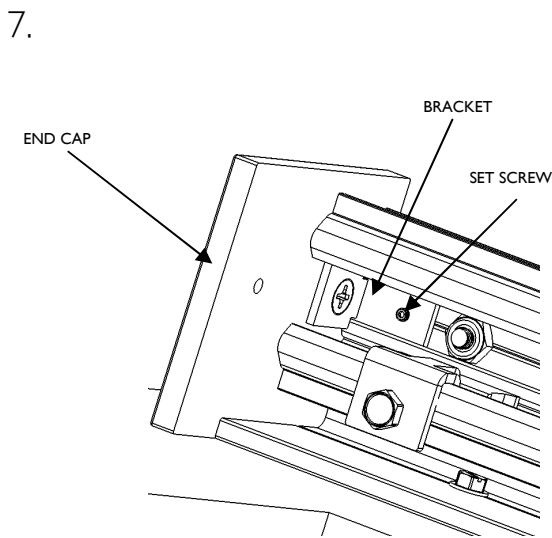

- A. ASSEMBLE THE BRACKET TO THE END CAP (NOTE THE END CAP HAS TWO HOLE PLACEMENT LOCATIONS FOR LEFT OR RIGHT APPLICATION).
- B. SLIDE THE ASSEMBLY INTO THE TRACK AND LOCK IT IN PLACE WITH THE SET SCREW.

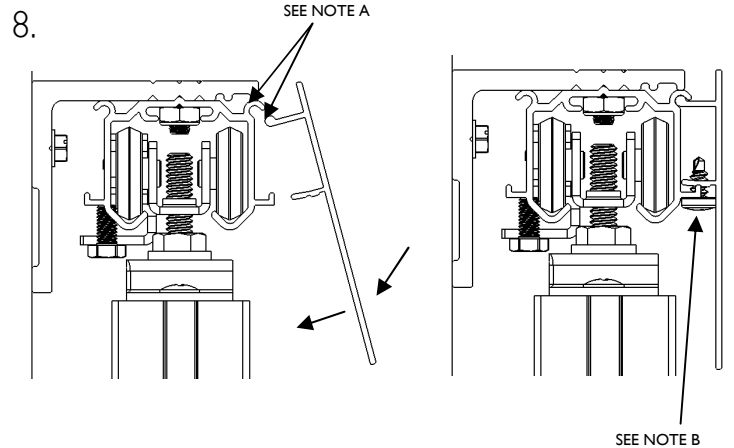

- A. INSERT FASCIA INTO TRACK AND ROTATE IT UNTIL IT SNAPS INTO PLACE.
- B. SECURE FASCIA USING #6 X 3/8" TEK SCREWS.